

A

Structure

Building Regulations 2012

Technical Guidance Document



Comhshaol, Pobal agus Rialtas Áitiúil
Environment, Community and Local Government



Building Regulations 2012

Technical Guidance Document A

Structure

ARNA FHOILSIÚ AG OIFIG AN tSOLÁTHAIR
BAILE ÁTHA CLIATH

Le ceannach díreach ón
OIFIG DHÍOLTA FOILSEACHÁIN RIALTAIS,
TEACH SUN ALLIANCE, SRÁID THEACH LAIGHEAN, BAILE ÁTHA CLIATH 2,
nó tríd an bpost ó
FOILSEACHÁIN RIALTAIS, AN RANNÓG POST-TRÁCHTA,
AONAD 20 PÁIRC MIONDÍOLA COIS LOCHA, CLÁR CHLAINNE MHUIRIS, CONTAE MHAIGH EO
(Teil: 01-6476834/37 nó 1890 213434; Fax: 01-6476843 nó 094-9378964)
nó trí aon díoltóir leabhar.

PUBLISHED BY THE STATIONERY OFFICE
DUBLIN

To be purchased directly from the
GOVERNMENT PUBLICATIONS SALE OFFICE
SUN ALLIANCE HOUSE, MOLESWORTH STREET, DUBLIN 2,
or by mail order from
GOVERNMENT PUBLICATIONS, POSTAL TRADE SECTION,
UNIT 20 LAKESIDE RETAIL PARK, CLAREMORRIS, CO. MAYO
(Tel: 01-6476834/37 or 1890 213434; Fax: 01-6476843 or 094-9378964)
or through any bookseller.

Price €6.00

ISBN 978-1-4064-2702-8

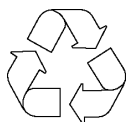

Printed on recycled paper containing a
minimum of 75% post-consumer waste



Comhshaol, Pobal agus Rialtas Áitiúil
Environment, Community and Local Government

© Government of Ireland 2012

Contents

Building Regulations 2012

Technical Guidance Document A

Structure			Page
Introduction			3
Transitional Arrangements			3
The Guidance			3
Existing Buildings			3
Technical Specifications			3
Materials and Workmanship			4
Interpretation			4
Part A - The Requirement			5
Section 1			
Structure – Loading and ground movement			6
Introduction			6
Other approaches			8
Definitions			8
Sub-section 1			
Sizes for certain structural elements for houses and other small buildings			9
1.1.1	Part 1	Basic requirements for stability	9
1.1.2	Part 2	Sizes of certain timber floor, ceiling and roof members in houses	10
		Application	10
		The use of this Part	10
1.1.3	Part 3	Thickness of masonry walls in houses with not more than two floors including the ground floor	10
		Application	10
		The use of this Part	11
		Wall types	11
		Wall construction	11
		External walls	11
		Internal load bearing walls	11
		Materials	11
		Solid concrete blocks	11
		Lightweight solid concrete blocks	11
		Hollow concrete blocks	11
		Clay bricks	12
		Other masonry units	12
		Lintels	12
		Mortar	12

		Wall ties	12
		Maximum loads	12
		Maximum height of buildings	12
		Retained earth	16
		Limitations on building geometry	16
		Lateral support and end restraint	16
		Buttressing	16
		Openings and chases in walls	20
		Interaction of elements	20
1.1.4	Part 4	Proportions for masonry chimneys above the roof surface	26
		Height to width relationship	26
1.1.5	Part 5	Strip foundations of plain concrete	26
		Conditions relating to the sub-soil	26
		Design provisions	26
		Minimum width of strip foundations	27
Sub-section 2			
Design and construction of all building types - codes, standards and references			29
		Introduction	29
		Codes, standards and references	29
Sub-section 3			
Recovering of existing roof structures and structural safety of external wall cladding			32
		Recovering of existing roof structures	32
		Structural safety of external wall cladding	32
		Technical approach	33
		Loading	33
		Fixings	33
		Further guidance on fixings	33
		Codes and standards	34
Section 2			
Disproportionate collapse			35
		Introduction	35
		Disproportionate collapse	35
		Step 1 - Determine building consequence class	35
		Step 2 – Assess additional measures	36
		Step 3 - Design and construct additional measures	36
		Definitions	37
Standards and publications			40
		Other standards and publications	45

Building Regulations 2012

Technical Guidance Document A - Structure

Introduction

This document has been published by the Minister for the Environment, Community and Local Government under article 7 of the Building Regulations 1997. It provides guidance in relation to Part A of the Second Schedule to the Regulations. The document should be read in conjunction with the Building Regulations 1997-2012, and other documents published under these Regulations.

In general, Building Regulations apply to the construction of new buildings and to extensions and material alterations to buildings. In addition, certain parts of the Regulations apply to existing buildings where a material change of use takes place. Otherwise, Building Regulations do not apply to buildings constructed prior to 1 June, 1992.

Transitional Arrangements

This document applies to works, or buildings in which material changes of use takes place, where the works or the change of use commence or take place, as the case may be, on or after 1 July 2013. Technical Guidance Document A - Structure, dated 1997 also ceases to have effect from that date. However, the latter document may continue to be used in the case of works, or buildings in which a material change of use takes place where the works or the change of use commence or takes place, as the case may be, before 30 June 2013.

The Guidance

The materials, methods of construction, standards and other specifications (including technical specifications) which are referred to in this document are those which are likely to be suitable for the purposes of the Regulations. Where works are carried out in accordance with the guidance in this Document, this will, prima facie, indicate compliance with Part A of the Second Schedule to the Building Regulations. However, the adoption of an approach other than that outlined in the guidance is not precluded provided that the relevant requirements of the Regulations are complied

with. Those involved in the design and construction of a building may be required by the relevant building control authority to provide such evidence as is necessary to establish that the requirements of the Building Regulations are being complied with.

Existing Buildings

In the case of material alterations or changes of use of existing buildings, the adoption without modification of the guidance in this document may not, in all circumstances, be appropriate. In particular, the adherence to guidance, intended for application to new work may be unduly restrictive or impracticable. Buildings of architectural or historical interest are especially likely to give rise to such circumstances. In these situations, alternative approaches based on the principles contained in the document may be more relevant and should be considered.

Technical Specifications

Building Regulations are made for specific purposes, e.g. to provide, in relation to buildings, for the health, safety and welfare of persons, the conservation of energy and access for people with disabilities. Technical specifications (including harmonised European Standards, European Technical Approvals, National Standards and Agrément Certificates) are relevant to the extent that they relate to these considerations. Any reference to a technical specification is a reference to so much of the specification as is relevant in the context in which it arises. Technical specifications may also address other aspects not covered by the Regulations.

A reference to a technical specification is to the latest edition (including any amendments, supplements or addenda) current at the date of publication of this Technical Guidance Document. However, if this version of the technical specification is subsequently revised or updated by the issuing body, the new version may be used as a source of guidance provided that it continues to address the relevant requirements of the Regulations.

A list of other standards and publications that deal with matters relating to this Part of the Building Regulations is included at the end of this document. These standards and publications may be used as a source of further information but do not form part of the guidance.

Materials and Workmanship

Under Part D of the Second Schedule to the Building Regulations, building work to which the Regulations apply must be carried out with proper materials and in a workmanlike manner. Guidance in relation to compliance with Part D is contained in Technical Guidance Document D.

Interpretation

In this document, a reference to a section, subsection, part, paragraph or diagram is, unless otherwise stated, a reference to a section, subsection, part, paragraph or diagram, as the case may be, of this document. A reference to another Technical Guidance Document is a reference to the latest edition of a document published by the Minister for the Environment, Community and Local Government under article 7 of the Building Regulations 1997. Diagrams are used in this document to illustrate particular aspects of construction - they may not show all the details of construction.

Structure

Part A - The Requirement

Part A of the Second Schedule to the Building Regulations, as amended, provides as follows:

Loading.	A1	(1)	A building shall be designed and constructed, with due regard to the theory and practice of structural engineering, so as to ensure that the combined actions that are liable to act on it are sustained and transmitted to the ground - (a) safely, and (b) without causing such deflection or deformation of any part of the building, or such movement of the ground, as will impair the stability of any part of another building. (2) In assessing whether a building complies with sub-paragraph (1), regard shall be had to the variable actions to which it is likely to be subjected in the ordinary course of its use for the purpose for which it is intended.
Ground movement.	A2		A building shall be designed and constructed, with due regard to the theory and practice of structural engineering, so as to ensure that movements of the subsoil caused by subsidence, swelling, shrinkage or freezing will not impair the stability of any part of the building.
Disproportionate Collapse.	A3	(1)	A building shall be designed and constructed, with due regard to the theory and practice of structural engineering, so as to ensure that in the event of an accident the structure will not be damaged to an extent disproportionate to the cause of the damage. (2) For the purposes of sub-paragraph (1), where a building is rendered structurally discontinuous by a vertical joint, the building on each side of the joint may be treated as a separate building whether or not such joint passes through the substructure.
Definitions for this Part.	A4		In this Part - “actions” means a set of forces (loads) applied to the structure (direct actions) or a set of imposed deformations or accelerations (indirect actions). “variable actions” means actions for which the variation in magnitude with time is neither negligible nor monotonic such as imposed loads on building floors, wind actions or snow loads.

Section 1

Structure – Loading and ground movement

This Technical Guidance Document is divided into two sections.

Section 1 relates to the requirements in A1 and A2.

Section 2 relates to the requirement in A3.

Section 1

Structure - Loading and ground movement

Loading.	A1	(1)	A building shall be designed and constructed, with due regard to the theory and practice of structural engineering, so as to ensure that the combined actions that are liable to act on it are sustained and transmitted to the ground -
		(a)	safely, and
		(b)	without causing such deflection or deformation of any part of the building, or such movement of the ground, as will impair the stability of any part of another building.
		(2)	In assessing whether a building complies with sub-paragraph (1), regard shall be had to the variable actions to which it is likely to be subjected in the ordinary course of its use for the purpose for which it is intended.
Ground movement.	A2		A building shall be designed and constructed, with due regard to the theory and practice of structural engineering, so as to ensure that movements of the subsoil caused by subsidence, swelling, shrinkage or freezing will not impair the stability of any part of the building.

Introduction

1.0.1 The safety of a structure depends on the successful combination of design and execution, particularly:

- (a) The design should be based on identification of the hazards to which the structure is likely to be subjected and assessment of risks. The selection of relevant critical situations for design should be made reflecting the conditions that can reasonably be foreseen during future use;
- (b) Actions (both direct and indirect);
- (c) Properties of materials;
- (d) Design analysis;

- (e) Details of construction;
- (f) Safety factors;
- (g) Workmanship and execution.

The Eurocodes are a set of harmonised European structural design codes for building and civil engineering works and are produced by CEN (European Committee for Standardisation) on foot of a mandate from the EU Commission. The Eurocodes are intended to remove potential barriers to trade that exist when countries have different design standards. There are 10 Eurocodes made up of 58 Parts as follows:

- EN 1990 – Eurocode: Basis of Structural Design (1 Part);

-
- EN 1991 – Eurocode 1: Actions on Structures (10 Parts);
 - EN 1992 – Eurocode 2: Design of Concrete Structures (4 Parts);
 - EN 1993 – Eurocode 3: Design of Steel Structures (20 Parts);
 - EN 1994 – Eurocode 4: Design of Composite Steel and Concrete Structures (3 Parts);
 - EN 1995 – Eurocode 5: Design of Timber Structures (3 Parts);
 - EN 1996 – Eurocode 6: Design of Masonry Structures (4 Parts);
 - EN 1997 – Eurocode 7: Geotechnical Design (2 Parts);
 - EN 1998 – Eurocode 8: Design of Structures for Earthquake Resistance (6 Parts),*
 - EN 1999 – Eurocode 9: Design of Aluminium Structures (5 Parts).
- (i) for densities, self weight and imposed loadings, I.S. EN 1991-1-1:2002 (Eurocode 1);
 - (ii) for accidental actions, I.S. EN 1991-1-7:2006 (Eurocode 1);
 - (iii) for snow loadings, I.S. EN 1991-1-3:2003 (Eurocode 1);
 - (iv) for wind actions, I.S. EN 1991-1-4:2005 (Eurocode1);
 - (v) for earth retaining structures, I.S. EN 1997-1:2004 (Eurocode 7);
 - (vi) any greater loadings to which the building is likely to be subjected (Eurocode 1).

The reliability of designs carried out in accordance with the Eurocodes is based on a number of assumptions set out in I.S. EN 1990: 2002. These general assumptions are as follows:

- The choice of the structural system and the design of the structure are made by appropriately qualified and experienced personnel;
- The execution of the work is carried out by personnel having the appropriate skill and experience;
- Adequate supervision and quality control is provided during design and during execution of the work;
- The construction materials and products are used as specified in I.S. EN 1990 or in I.S. EN 1991 to I.S. EN 1999 or in the relevant execution standards, or reference material or product specifications;
- The structure will be adequately maintained, and
- The structure will be used in accordance with the design assumptions.

Each Part is implemented nationally with a National Annex. These Annexes contain information on Nationally Determined Parameters to be used for the design of building and civil engineering works to be constructed in the country concerned, addressing for example particular national safety parameters, geographical and climatic conditions, and procedures. Irish National choices are contained in the Irish National Annex or National Foreword to each Part. Therefore, any reference to the Eurocodes must be taken to include reference to the relevant Irish National Annex.

As regards (a) and (b) above, the actions to which a building is subjected should be calculated in accordance with the appropriate Eurocode i.e.

* Not relevant in Ireland

In relation to the final two bullet points above, whilst the provisions of the Building Regulations do not relate to management or maintenance and compliance with the Regulations is not dependent on these, it is acknowledged that they are fundamental to the safety of structures.

The use of the Eurocodes referenced in this document is a practical guidance on meeting the Requirements of Part A. A full list of the relevant Eurocodes and execution standards is included in the 'Standards and publications' section of this Technical Guidance Document and references are made in the text where appropriate.

1.0.2 This Section comprises three sub-sections:

Sub-section 1 of the document applies to small buildings with walls of traditional masonry construction and with timber first floors and roofs. It gives sizes for certain elements in houses with not more than two floors including the ground floor. This sub-section also applies to domestic garages and other annexes attached to such houses.

For the design of timber frame dwellings refer to I.S. 440.

The sub-section is arranged in five parts as follows:

Part 1: - Basic requirements for stability.

Part 2: - Sizes of certain timber floor, ceiling and roof members in houses with not more than two floors, including the ground floor.

Part 3: - Thickness of masonry walls in houses with not more than two floors including the ground floor.

Part 4: - Proportions for masonry chimneys above the roof surface.

Part 5: - Strip foundations of plain concrete.

Part 1 gives general rules which must be observed in using Parts 2 and 3. Parts 2 to 5 may be used independently of each other.

Sub-section 2 is relevant to all building types and lists standards for structural design and execution but, where these do not give precise guidance, regard should be had to par. 1.0.1.

Sub-section 3 provides guidance for recovering of existing roof structures and the structural safety of external wall cladding.

Other approaches

1.0.3 If other approaches are adopted, it is essential to have regard to par. 1.0.1 and to the following:

- (a) The numerical values of safety factors, whether expressed explicitly or implicitly in design equations or design values, should be derived from considerations of the aspects of design and construction given in par. 1.0.1 as a whole. A change in any one of these aspects may affect the safety of the structure;
- (b) Actions used in calculations should allow for possible dynamic, concentrated and peak load effects that may occur. The design should ensure that the effects of actions have been evaluated with an appropriate degree of reliability.

Definitions

1.0.4 The following definitions apply to Section 1:

Actions – Set of forces (loads) applied to the structure (direct action), or a set of imposed deformations or accelerations (indirect actions) caused for example by temperature changes or uneven settlement.

Actions are classified by their variation in time and include the following (For full definitions of all terminology relating to actions and other action types refer to I.S. EN 1990):

- **Permanent action (G)** – Action that is likely to act throughout a given reference period and for which the variation in magnitude with time is negligible, or for which the variation is always in the same direction (monotonic) until the action attains a certain limit value e.g. self weight of structures, fixed equipment etc; and indirect actions caused by e.g. shrinkage and uneven settlements etc;
- **Variable action (Q)** – Action for which the variation in magnitude with time is neither negligible nor monotonic e.g. imposed loads on building floors, wind actions or snow loads;
- **Accidental action (A)** – Action, usually of short duration but of significant magnitude, which is unlikely to occur on a given structure during the design working life. An accidental action e.g. due to fire, local failure, explosions or impact from vehicles, etc can be expected in many cases to cause severe consequences unless appropriate measures are taken.

Buttressing wall – A wall designed and constructed to afford lateral support to another wall perpendicular to it, support being provided from the base to the top of the wall.

Cavity width – The horizontal distance between the two leaves of a cavity wall.

Compartment wall - A wall constructed as a compartment wall to meet the requirements of Part B (Fire Safety) of the Second Schedule to the Building Regulations.

Execution – This covers all activities carried out for the physical completion of the work. The term covers work on site; it may also signify the fabrication of components off site and their subsequent erection on site.

Imposed load – Imposed loads on buildings are those arising from occupancy e.g. normal use by persons, furniture and moveable objects (e.g. moveable partitions, storage), vehicles, and anticipated rare events, such as

concentrations of persons or of furniture, or the moving or stacking of objects which may occur during reorganisation or redecoration.

Pier – A member which forms an integral part of a wall, in the form of a thickened section, so as to afford lateral support to the wall to which it is bonded or securely tied.

Self weight – (included in permanent actions) includes the structure and non-structural elements including fixed services as well as the weight of earth and ballast. Non-structural elements include roofing, surfacing and coverings, partitions, suspended ceilings, wall cladding, thermal insulation, fixed services e.g. electrical, plumbing, heating, ventilating, air conditioning etc.

Separating wall – A wall or part of a wall which is common to adjoining buildings and constructed to meet the requirements of Part B (Fire Safety) of the Second Schedule to the Building Regulations.

Spacing – The distance between the longitudinal centres of any two adjacent members of the same type, measured in the plane of floor, ceiling, roof, or other part of the structure of which members form a part.

Span – The distance measured along the centre line of a member between the centres of any two adjacent bearings or supports.

Supported wall – A wall to which lateral support is afforded by a combination of buttressing walls, piers or chimneys acting in conjunction with floor(s) or roof.

Sub-section 1

Sizes for certain structural elements for houses and other small buildings

Part 1 - Basic requirements for stability

1.1.1.1 This Part must be used in conjunction with Parts 2 and 3 of this sub-section.

1.1.1.2 Trussed rafter roofs should be braced in accordance with the recommendations of I.S. 193. Where, due to its form of

construction, a traditionally framed roof (i.e. using rafters, purlins and ceiling joists) does not have sufficient built-in resistance to instability, for example from hipped returns, then bracing is required.

1.1.1.3 If the roof structure is braced as described above and adequately anchored to the structure beneath and the walls are designed and restrained in accordance with the requirements of Part 3 of this sub-section, no special provision should be needed to take account of loads due to the effect of wind pressure or suction. However, par. 1.1.3.26 gives details of situations in which additional ties may be required.

Part 2 - Sizes of certain timber floor, ceiling and roof members in houses

Application

1.1.2.1 This Part applies only to houses (Category A1 buildings as defined in I.S. EN 1991-1-1) with not more than two floors including the ground floor.

The use of this Part

1.1.2.2 This Part must be used in conjunction with Part 1 of this sub-section.

1.1.2.3 The guidance given in this Part assumes that:

- (a) the permanent and variable actions to be sustained by the floor, ceiling or roof of which the member forms part do not exceed the values given in Table 1 for a Category A1 building;
- (b) the species of timber and grade combinations for allocation to strength classes are those given in I.S. EN 1912;
- (c) the strength and stiffness properties and density strength class is in accordance with I.S. EN 338, and
- (d) floor boarding complying with BS 1297: 1987 is used.

1.1.2.4 Target sizes and permissible deviations should be in accordance with I.S. EN 336.

1.1.2.5 Notches and holes in simply supported floor and roof joists should be within the following limits:

- (a) notches should be no deeper than 0.125 times the depth of a joist and should not be cut closer to the support than 0.07 times the span, nor further away than 0.25 times the span,
- (b) holes should be no greater diameter than 0.25 times the depth of the joist, should be drilled at the neutral axis, should be not less than three diameters (centre to centre) apart and should be located between 0.25 and 0.4 times the span from the support, and
- (c) the horizontal distance between any hole and any notch should not be less than the depth of the joist.

1.1.2.6 Bearing areas and workmanship should comply with the relevant requirements of I.S. EN 1995-1-1. Refer also to par 1.1.3.22 to 1.1.3.25 of this document.

1.1.2.7 Timber joists, rafters and purlins should be designed in accordance with I.S. EN 1995-1-1 for the loadings (actions) calculated in accordance with the appropriate Eurocode.

Part 3 - Thickness of masonry walls in houses with not more than two floors including the ground floor

Application

1.1.3.1 This Part applies to houses (Category A1 buildings as defined in I.S. EN 1991-1-1) with not more than two floors including the ground floor, with walls of traditional masonry construction, with timber upper floors and with roofs covered with normal lightweight covering including clay or concrete pantiles. It also applies to domestic garages and other annexes attached to such houses.

For the design of timber frame dwellings refer to I.S. 440.

The use of this Part

1.1.3.2 This Part must be used in conjunction with Part 1 of this sub-section. All appropriate design conditions given in this part must be satisfied. Walls should comply with the relevant requirements of I.S. EN 1996-2 and additional guidance given in prS.R. 325. The wall types given in par. 1.1.3.3 may be constructed as described in par. 1.1.3.4 using the materials described in par. 1.1.3.5 and subject to the requirements of pars. 1.1.3.6 to 1.1.3.27.

Wall types

1.1.3.3 This Part applies to external walls and internal walls (including compartment walls and separating walls).

Wall construction

1.1.3.4 General wall thicknesses may be determined according to this section.

External walls

- (a) Cavity walls constructed using two leaves composed of either, solid concrete blocks or bricks of not less than 100 mm thickness, or of clay bricks, tied together with wall ties appropriate to the width of cavity. The inner leaf may be constructed using minimum 100 mm thick lightweight solid concrete blocks;
- (b) Cavity block walls constructed using 215 mm hollow concrete blocks.

Internal load bearing walls

- (a) Internal load bearing walls composed of solid or lightweight solid concrete blocks or bricks;
- (b) Separating walls composed of 215 mm thick solid concrete blocks (refer to Technical Guidance Document E for guidance on sound insulation);

- (c) Separating walls of cavity construction composed of two leaves of solid concrete blocks of not less than 100 mm thickness (refer to Technical Guidance Document E for guidance on sound insulation).

Materials

1.1.3.5 Walls should be properly bonded and solidly put together with mortar and comply with the relevant requirements of I.S. EN 1996-2 and additional guidance given in prS.R. 325. The materials used should meet the following minimum designations, strengths and other qualities.

Solid concrete blocks

Solid concrete blocks should have a thickness as required by par 1.1.3.4 and be Group 1 masonry units conforming to I.S. EN 771-3. The declared mean compressive strength for Group 1¹ masonry units should be 7.5N/mm² (dry strength to I.S. EN 772-1);

Lightweight solid concrete blocks

Lightweight solid concrete blocks should have a thickness as required by par 1.1.3.4 and be Group 1 masonry units conforming to I.S. EN 771-3.

The declared mean compressive strength for Group 1 masonry units should be 7.5N/mm² (dry strength to I.S. EN 772-1);

Hollow concrete blocks

Hollow concrete blocks should have a thickness as required by par 1.1.3.4 and be Group 2² masonry units conforming to I.S. EN 771-3. The declared mean compressive strength for Group 2 masonry units to this standard should be 4.5N/mm² (dry strength to I.S. EN 772-1);

¹ Group 1 masonry units have not more than 25% formed voids (20% for frogged bricks).

² Group 2 masonry units have formed voids greater than 25%, but not more than 55%.

Clay bricks

Clay bricks should have a thickness of 103 mm, be frost resistant and conform to I.S. EN 771-1 and may be either Group 1 or Group 2 masonry units. The declared mean compressive strength for Group 1 masonry units should be 9N/mm² and 13 N/mm² for Group 2 masonry units;

Other masonry units

Other masonry units should have strength and thickness equivalent to those listed above and should conform to the following standards.

- Calcium silicate masonry units conforming to I.S. EN 771-2;
- Autoclaved aerated concrete masonry units conforming to I.S. EN 771-4;
- Manufactured stone masonry units conforming to I.S. EN 771-5;
- Natural stone masonry units conforming to I.S. EN 771-6.

Lintels

Lintels should be designed for the actions and spans occurring where they are employed and should be installed strictly in accordance with the manufacturers' instructions. Prefabricated lintels should comply with I.S. EN 845-2 and additional guidance given in prS.R. 325.

Mortar

Mortar should be:

- (a)
- (i) mortar designation (iii) according to I.S. EN 1996-1-1;
 - (ii) strength class M4 according to I.S. EN 998-2 (nominally a 1:1:5 or 6 mixture of CEM I, lime and fine aggregate measured by volume of dry materials),
or
- (b) of equivalent or greater strength and durability to the specification in (a) above.

Wall ties

Wall ties should comply with I.S. EN 845-1 and should be material references 1 or 3 in I.S. EN 845 Table A1 austenitic stainless steel. Wall ties should be selected in accordance with Table NA.1 of I.S. EN 845-1.

Maximum loads

Vertical actions

1.1.3.6 The design considerations given in this section are intended to be adequate for the vertical actions given in Table 1.

Table 1 Design actions				
Element	Permanent actions UDL kN/m ²	Variable actions		
		UDL kN/m ²	Concentrated kN	Snow kN/m ²
Roofs	0.60*	0.60	1.0	0.7
Floors	0.30*	1.50	2.0	-
Ceilings	0.30*	0.25	0.9	-

*excluding self weight of member

Maximum height of buildings

1.1.3.7 The design guidance in this section is based on I.S. EN 1991-1-4. The maximum allowable height of a building (to ridge level) within the scope of Part 3 may be derived using the procedure set out in Diagram 1. The values given in Table 4 correlate to various site exposure conditions and wind speeds. A map showing wind speeds is given in Figure 1a of Diagram 1.

Where more exposed terrain is involved or where there is reason to believe that higher wind speeds may pertain e.g. due to funnelling effects etc, a separate design check in accordance with I.S. EN 1991-1-4 should be carried out. Part 3 of this Technical Guidance Document is not applicable if the site peak velocity pressure determined in this manner exceeds 1.2 kN/m².

Diagram 1 Maximum height of buildings
(Par. 1.1.3.7)

Procedure for calculating the maximum allowable building height

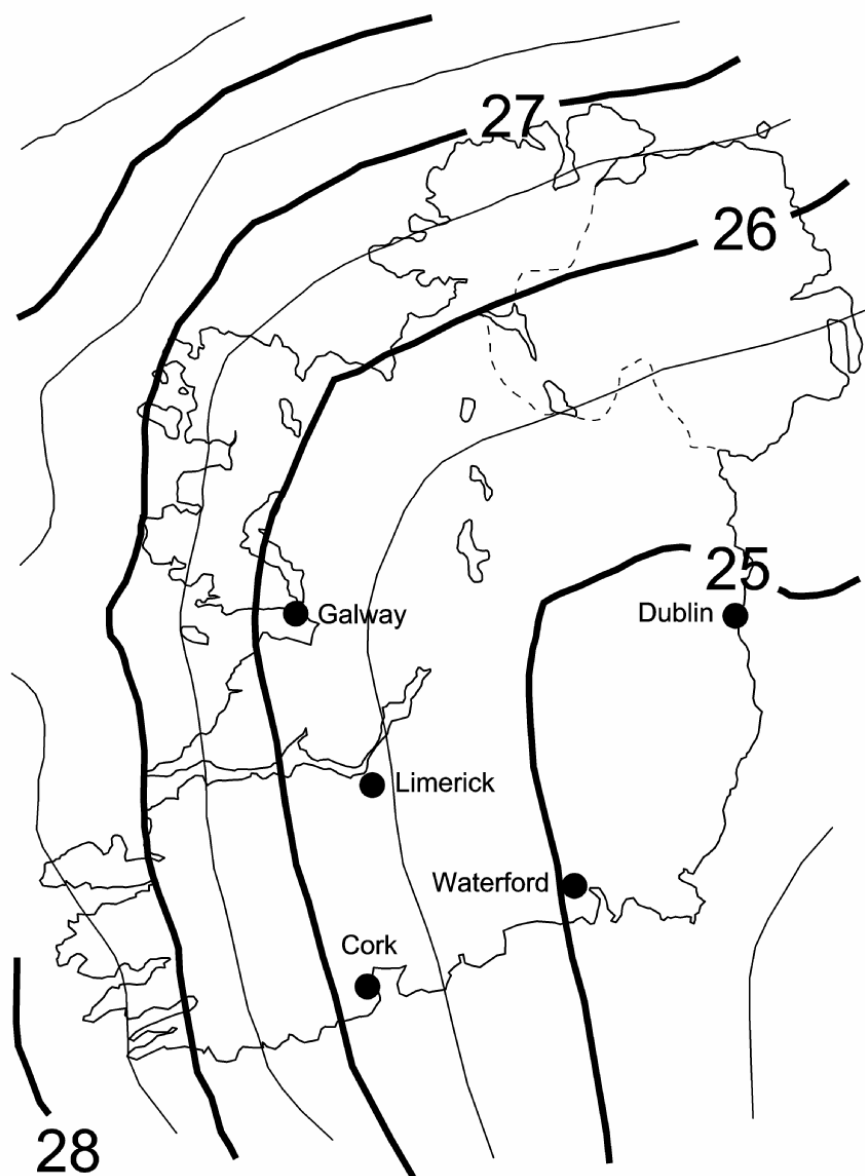
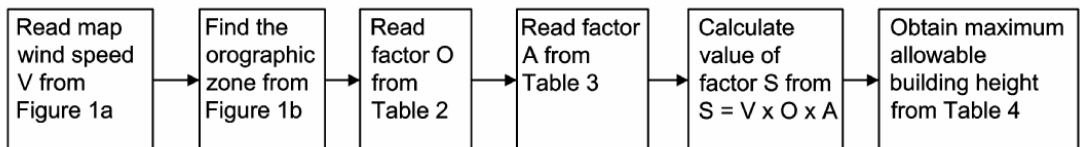

Figure 1(a) Map of wind speeds (v) in m/s

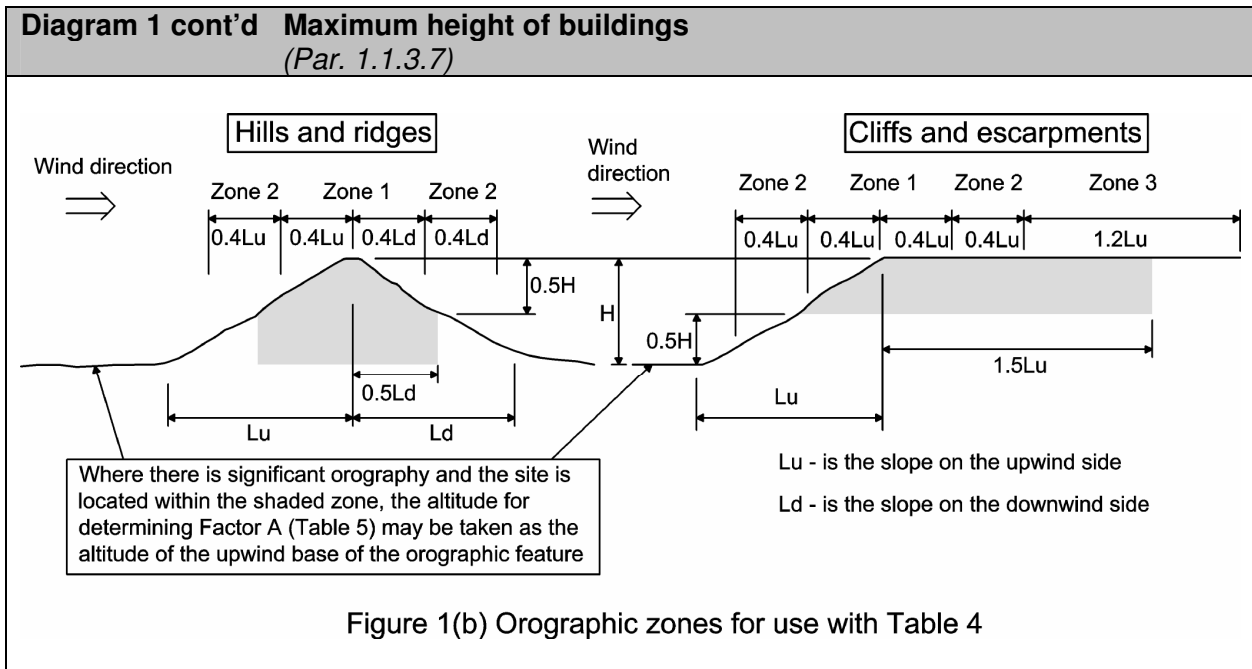

Table 2 Factor O (See Diagram 1 - Figure 1b)			
Terrain type and average slope of whole hillside, ridge, cliff or escarpment	Factor O ⁽ⁱ⁾		
	Zone 1	Zone 2	Zone 3
Nominally flat terrain, average slope $\psi \leq 1:20$	1.0	1.0	1.0
Moderately steep terrain, average slope $\psi > 1:20$ but $\leq 1:5$	1.24	1.13	1.10
Steep terrain, average slope $\psi > 1/5$ but $\leq 1:3.3$ ⁽ⁱⁱ⁾	1.36	1.20	1.15

Notes:

(i) The orography factor, accounts for the increase of mean wind speed over isolated hills and escarpments. Outside of the above zones Factor O = 1.0.

(ii) Average slopes $\psi > 1:3.3$ are outside the scope of this guidance, refer to I.S. EN 1991-1-4.

Table 3 Factor A (See Note below)											
Site altitude above mean sea level (m)	0	50	100	150	200	250	300	350	400	450	500
Factor A	1.00	1.05	1.10	1.15	1.20	1.25	1.30	1.35	1.40	1.45	1.50
Note: Where there is significant orography i.e. moderately steep or steep terrain, and the site is located within the shaded zone in Diagram 1 - Figure 1b, then the altitude for determining Factor A may be taken as the altitude of the upwind base of the orographic feature instead of the altitude at the site.											

Table 4 Maximum allowable building height in metres to ridge level
(Par. 1.1.3.7)

Factor S S = (V x O x A)	Country sites ³			Town sites ⁴		
	Distance to the coast (see Note 2)			Distance to the coast (see Note 2)		
	<2 km	2 – 20 km	>20 km	<2 km	2 – 20 km	>20 km
≤26	10.0	10.0	10.0	10	10	10
27	8.0	10.0	10.0	10	10	10
28	6.0	8.0	10.0	10	10	10
29	4.0	6.0	8.0	10	10	10
30	3.0	5.0	6.5	9.0	10	10
31	-	4.0	5.5	8.0	9.5	10
32	-	3.0	4.5	7.0	8.5	10
33	-	-	3.5	6.0	8.0	9.0
34	-	-	3.0	5.5	7.5	8.5
35	-	-	-	4.5	6.5	7.5
36	-	-	-	4.0	6.5	7.0
37	-	-	-	3.5	6.0	6.5
38	-	-	-	3.0	5.0	6.0
39	-	-	-	-	4.5	5.5
40	-	-	-	-	4.0	4.5
41	-	-	-	-	3.5	4.0
42	-	-	-	-	3.0	3.5
43	-	-	-	-	-	3.0
>43	-	-	-	-	-	-

Notes:

1. For sites on the outskirts of towns, or not surrounded by other buildings, use the values for country sites;
2. Where a site is closer than 1km to an inland area of water which extends more than 1km in the wind direction, the distance to the coast should be taken as <2km.
3. Country Terrain includes:
 - (i) Lakes or area with negligible vegetation and without obstacles;
 - (ii) Area with low vegetation such as grass and isolated obstacles (trees, buildings) with separations of at least 20 obstacle heights.
4. Town Terrain includes:
 - (i) Area with regular cover of vegetation or buildings or with isolated obstacles with separations of maximum 20 obstacle heights (such as villages, suburban terrain, permanent forest);
 - (ii) Area in which at least 15 % of the surface is covered with buildings and their average height exceeds 15 m.

Retained earth

1.1.3.8 Differences in level of ground or other solid construction between one side of the wall and the other must be less than four times the thickness of the wall.

Limitations on building geometry

1.1.3.9 Residential buildings (see Diagram 2)

- (a) No part of any wall or roof should be more than 10 m above the lowest adjacent ground level.
- (b) The width of the building should not be less than half the height of the building.
- (c) The width of a wing should not be less than half the height of the wing when the projection P exceeds twice the width W_2 .

1.1.3.10 Floors should be as described below:

- (a) Ground floors - Timber floors or ground supported concrete floors or suspended concrete floors of maximum span 5 m.
- (b) Upper floors - Traditional timber floor of maximum span 5 m.

1.1.3.11 The floor to floor and ceiling to ceiling heights should not exceed 2.7 m.

1.1.3.12 The roof span should not exceed 12 m.

Lateral support and end restraint

1.1.3.13 The ends of every load-bearing wall should be bonded or otherwise securely tied throughout their full height to a buttressing wall pier or chimney. The maximum length of wall between vertical supports should not exceed 9 m. Longer walls should be provided with intermediate support, dividing the wall into distinct lengths, by buttressing walls, piers or chimneys, which provide support throughout the full height of the wall.

Diagram 2 Size and proportion of buildings
(Par. 1.1.3.9)

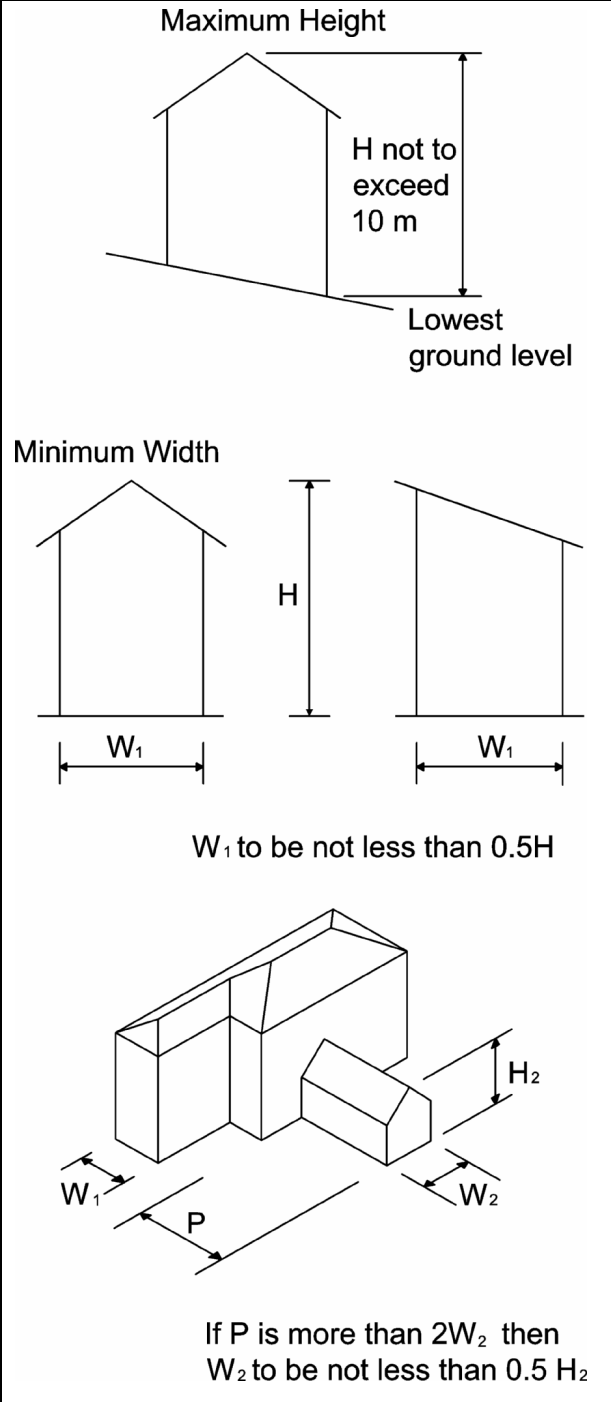

Buttressing

1.1.3.14 The thickness of the buttressing should not be less than 100 mm. Diagram 3 gives details of the limiting dimensions of openings and recesses in walls, including buttressing walls.

Diagram 3 Sizes of openings and recesses
(Par. 1.1.3.14)

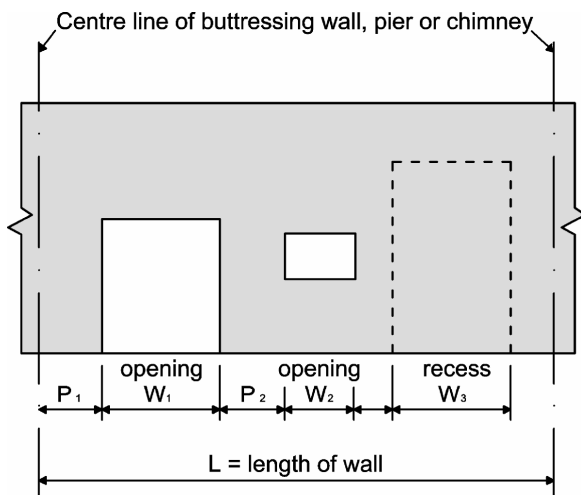

Requirements

1. $W_1 + W_2 + W_3$ should not exceed $\frac{2L}{3}$
2. W_1, W_2 or W_3 should not exceed 3 m
3. P_1 should be greater than or equal to $\frac{W_1}{6}$
4. P_2 should be greater than or equal to $\frac{W_1 + W_2}{3}$

1.1.3.15 Piers in solid walls should be not less than 190 mm in width and not less than 490 mm thick. Piers in hollow block walls should be not less than 190 mm in width and not less than 590 mm thick. Chimneys should be not less than 490 mm thick and be composed of units not less than 100 mm thick (see Diagram 4).

1.1.3.16 Internal buttressing to walls in upper floors may be provided by stud partitions not less than 1200 mm long constructed from 35 mm x 75 mm kiln dried timber with studs at not more than 400 mm centres and two rows of noggings. The end stud of the partition should be fixed to the wall using drilled screw fixings at the top and at each of the noggings. Reference should be made to Part L – Conservation of Fuel and Energy for guidance on limiting thermal bridging.

Diagram 4 Piers and chimneys
(Par. 1.1.3.15)

Note: All dimensions are minimum dimensions

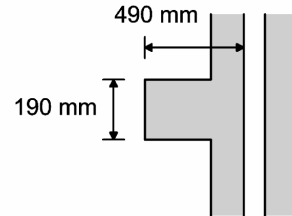

Pier in solid block walls

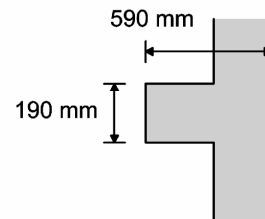

Pier in hollow block walls

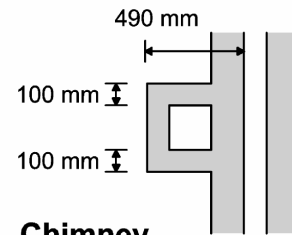

Chimney

1.1.3.17 Notwithstanding the rules in pars. 1.1.3.13 to 1.1.3.16, a supported wall may contain an unbuttressed section adjoining an opening as shown in Diagram 5 where –

- (a) the opening is in the ground storey of an external buttressing wall;
- (b) the opening does not exceed 2.4 m in height;
- (c) the supported wall is restrained at first floor level or, where the building is a single storey building, at roof level;
- (d) the supported wall is properly bonded to the buttressing wall below the ground floor level;

- (e) the supported wall is bonded to the buttressing wall above the opening by a beam or lintel spanning the opening in the buttressing wall;
- (f) the buttressing wall is properly bonded to a storey height wall, pier or chimney at the opposite side of the opening to the supported wall;

- (g) the supported wall is properly bonded to a storey height wall not more than 5.5 m from its unbuttressed section;
- (h) the beam or lintel described in (e) above is provided at each end with a bearing length of 400 mm or is supported on a padstone having a length of 400 mm.

Diagram 5 Unbuttressed wall sections
(Par. 1.1.3.17)

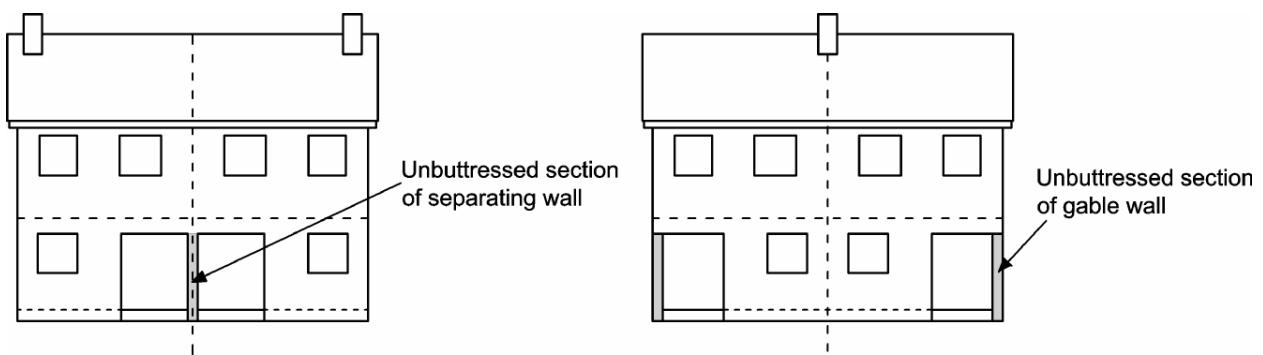

5 (a) Examples of unbuttressed wall sections

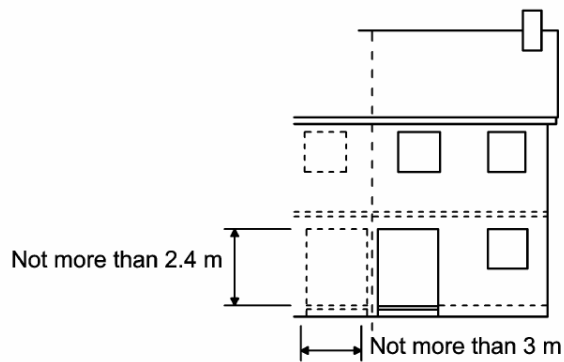

5 (b) Dimensional limitations of unbuttressed sections

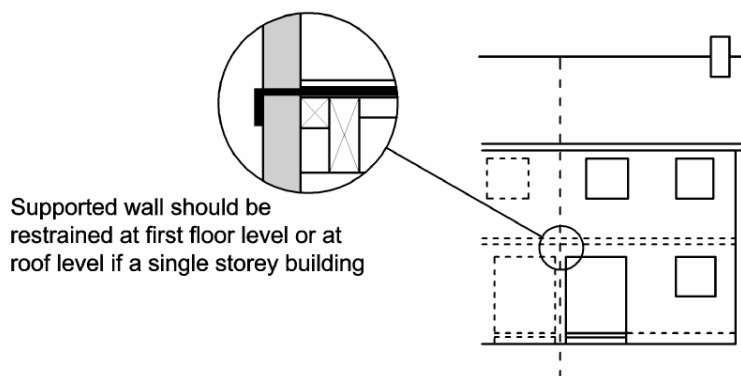

5 (c) Restraint at first floor level

Diagram 5 cont'd Unbutressed wall sections
 (Par. 1.1.3.17)

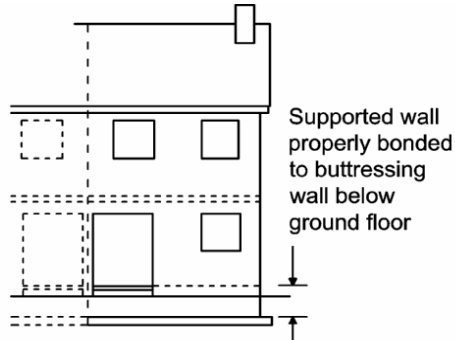

5 (d) Bonding of supported wall below ground floor

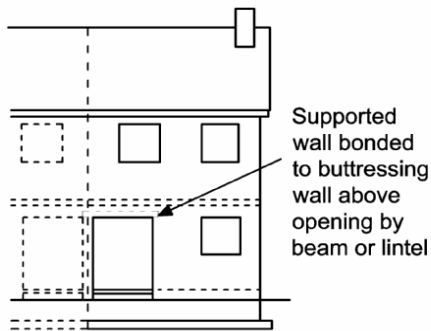

5 (e) Bonding of supported wall above ground storey opening

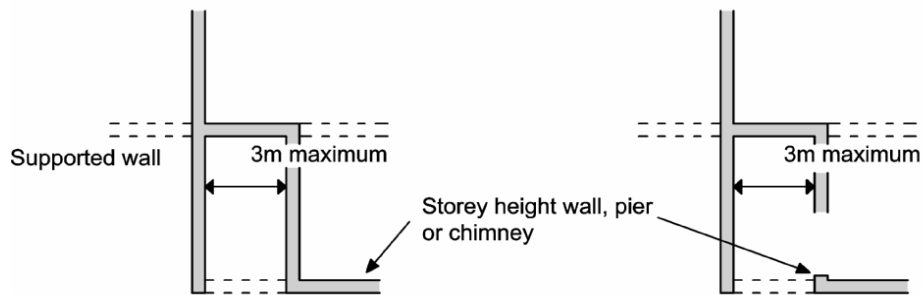

5 (f) Bonding of butressing wall at other side of opening

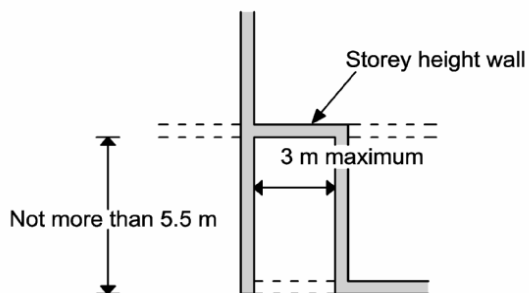

5 (g) Supported wall bonded to a storey height wall not more than 5.5 m from its unbutressed section

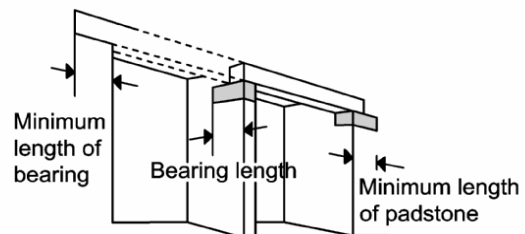

5 (h) Bearing lengths for beams or lintels

Openings and chases in walls

1.1.3.18 The number, size and position of openings should not impair the stability of a wall or the lateral support provided by a buttressing wall to a supported wall. Construction over openings and recesses should be adequately supported and the ends of lintels and beams should be provided with adequate bearing. All window and door lintels should have a minimum bearing length of 150 mm. In certain circumstances e.g. beam bearings, it may be necessary to provide padstones or longer bearings.

1.1.3.19 The maximum length of an opening or thickness-reducing recess in any wall should not exceed 3 m. Other dimensional criteria are given in Diagram 3 (see also par. 1.1.3.21).

1.1.3.20 Openings and thickness-reducing recesses in walls should not exceed 2.4 m in height (see also par. 1.1.3.21).

1.1.3.21 Dimensional criteria for chases

- (a) Chases should not impair the stability of the wall. Chases are not allowed when using hollow blocks.
- (b) Vertical chases formed after construction of masonry should not be deeper than 30 mm.
- (b) Horizontal or inclined chases should comply with the National Annex to I.S. EN 1996-1-1.

Further guidance on the maximum allowable widths of chases is given in the National Annex to I.S. EN 1996-1-1.

Interaction of elements

1.1.3.22 A wall in each storey of a building should extend to the full height of that storey and have horizontal lateral supports to restrict movement at right angles to its plane.

1.1.3.23 Floors and roofs should:

- (a) act to transfer lateral forces from walls to buttressing walls, piers or chimneys, and
- (b) be secured to the supported wall by connections specified in pars. 1.1.3.24 and 1.1.3.25.

1.1.3.24 Walls should be strapped to floors at first floor level at intervals not exceeding 2000 mm as shown in Diagram 6 (a) and (b) by 30mm x 5 mm galvanised mild steel or stainless steel tension straps which have a minimum 30 mm x 5 mm section conforming to I.S. EN 845-1. For corrosion resistance purposes, the tension straps should be material reference 14, 16.1 or 16.2 (galvanised steel) or other more resistant specifications including reference 1 or 3 (austenitic stainless steel). The declared tensile strength of tension straps should not be less than 8kN.

Straps need not be provided -

- (a) in the longitudinal direction of joists, if the joists are at not more than 800 mm centres and have at least
 - (i) 90 mm bearing on the supported walls, or
 - (ii) 75 mm bearing on a timber wall plate at each end,
- (b) in the longitudinal direction of joists where the joists are carried on the supported wall by joist hangers in accordance with I.S. EN 845-1 of the restraint type shown in Diagram 6 (c), at not more than 800 mm centres,
- (c) where floors are at or about the same level on each side of a supported wall as shown in Diagram 6 (d) and contact between floors and wall is either continuous or at intervals not exceeding 2000 mm. Where contact is intermittent, the point of contact should be in line or nearly in line on plan.

Diagram 6 Lateral support by floors

(Par. 1.1.3.24)

30 x 5 mm galvanised mild steel or other durable strap held tight against masonry wall

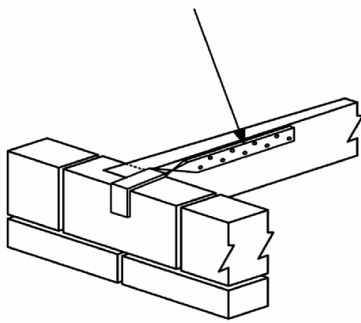

(a) Strap detail - 1

30 x 5 mm galvanised mild steel or other durable strap held tight against masonry wall

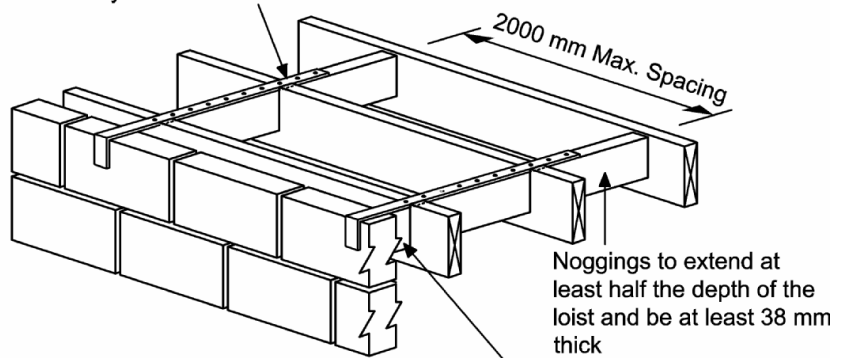

Note: The steel straps and noggings may alternatively be fixed to the underside of the floor joists

(b) Strap detail - 2

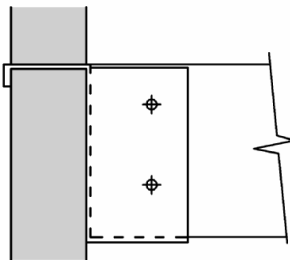

(c) Restraint type joist hanger

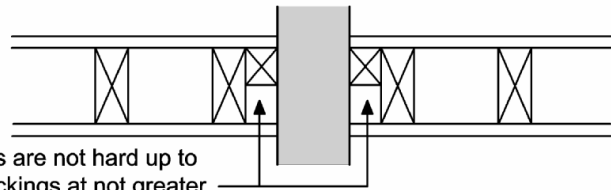

Where joists are not hard up to the wall blockings at not greater than 2 m centres should be used at the same locations on both sides of the wall

(d) Restraint of internal walls

1.1.3.25 Gable walls should be strapped to roofs as shown in Diagrams 7 (a) and (b) by 30 x 5 mm tension straps as described in 1.1.3.24. Vertical strapping at least 1000 mm in length should be provided at eaves level at intervals not exceeding 2000 mm as shown in Diagram 7 (c).

Additional vertical straps may be necessary in the following conditions and a separate design check should be carried out to calculate uplift in accordance with I.S. EN 1991-1-4. These conditions include where:

- (a) The roof has a pitch of less than 15°, and/or
- (b) With reference to Figure 1a of Diagram 1 the site wind speed is greater than 26 m/s, and/or
- (c) The building is located in exposed terrain and there is reason to believe that higher wind speeds may pertain.

1.1.3.26 Where an opening in a floor or roof, such as that required for a stairway (Diagram 8), adjoins a supported wall and interrupts the continuity of lateral support, the following conditions should be satisfied:

- (a) the length of opening should not exceed 3000 mm measured parallel to the supported wall;
- (b) where a connection is provided by means other than by anchor, this should be provided throughout the length of each portion of the wall situated on each side of the opening;
- (c) where connection is provided by mild steel or stainless steel anchors or by packs, these should be spaced closer than 2000 mm on each side of the opening to provide the same number as if there were no opening, and
- (d) there should be no other interruption of lateral support.

1.1.3.27 Wall ties should be provided in cavity walls and should comply with I.S. EN 845-1 and should be material references 1 or 3 in I.S. EN 845 Table A1 austenitic stainless steel. The minimum quantity of ties provided should be:

- 2.5 wall ties per square metre for cavity widths between 50mm and 75 mm;
- 3 wall ties per square metre for cavity widths between 75 mm and 100 mm, and
- 4.9 wall ties per square metre for cavity widths between of 100mm and 150 mm.

Extra wall ties are required at the jambs of openings and movement joints as shown in Diagram 9 (for use of ties in other cavity widths, see prS.R. 325).

Diagram 7 Lateral support at roof level

(Par. 1.1.3.25)

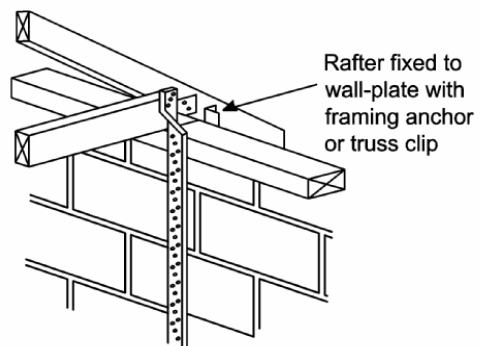
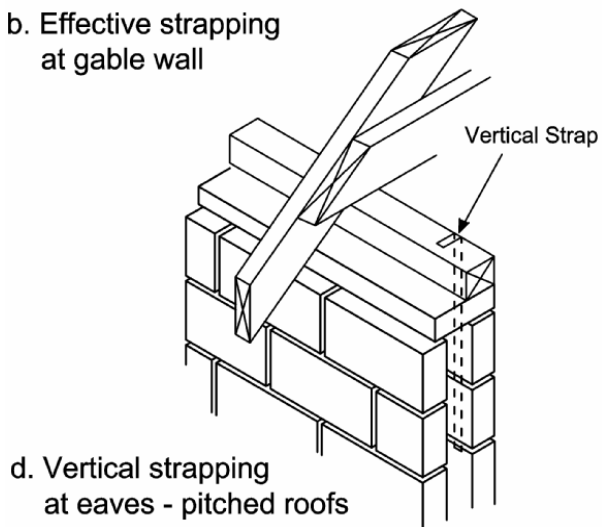
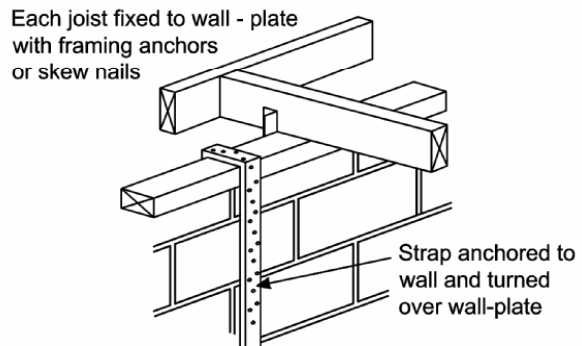
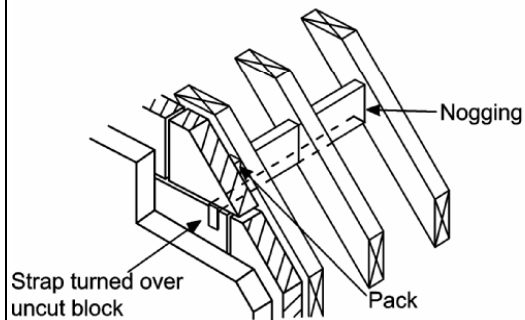
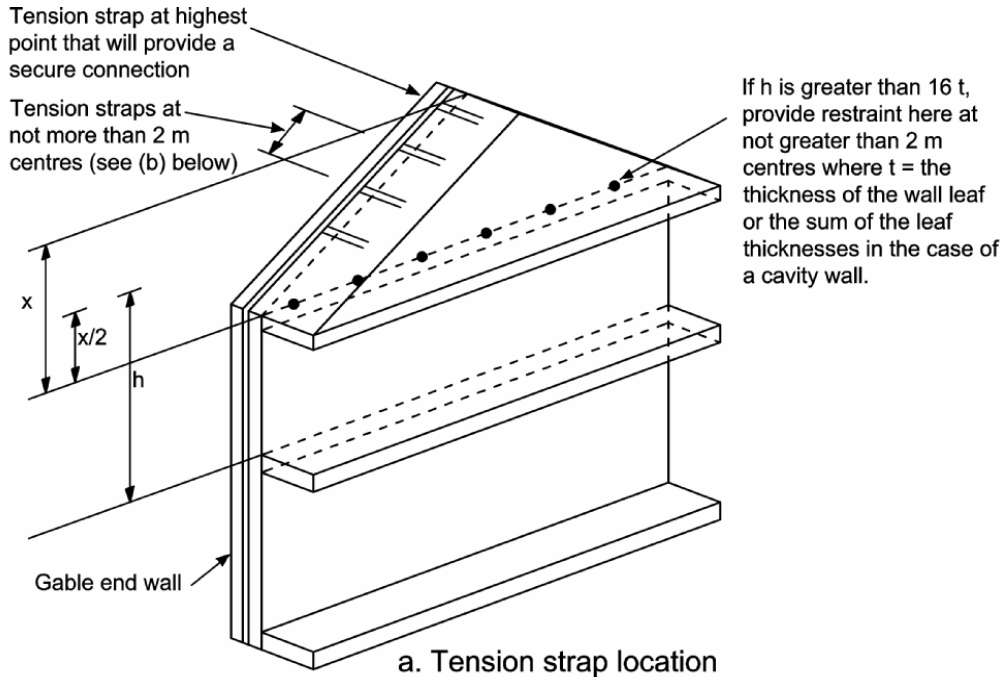
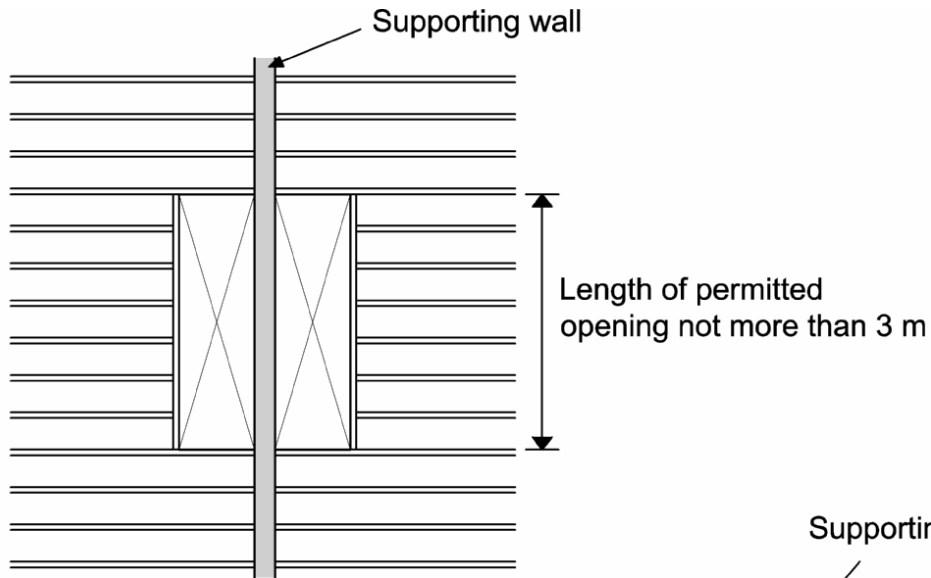
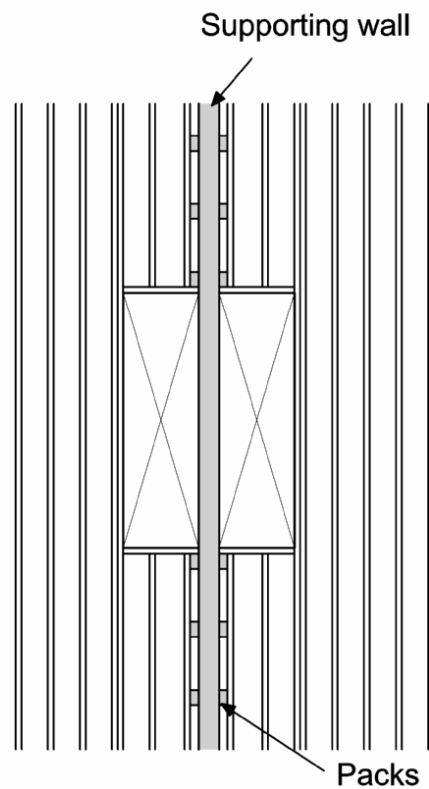

Diagram 8 Interruption of lateral support
(Par. 1.1.3.26)



Plan
 Connection provided by timber bearing on wall or by restraint type joist hanger



Plan
 Intermittent connection provided by packs. Additional packs required near opes.

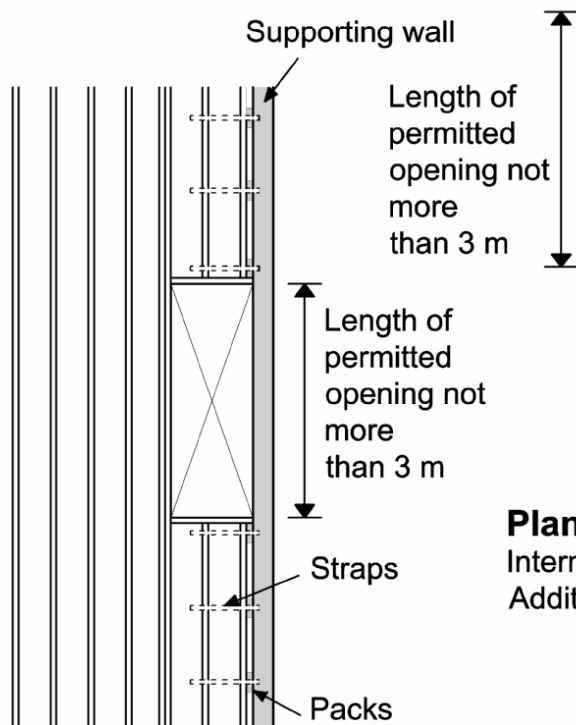

Plan
 Intermittent connection provided by straps. Additional straps required near opes.

Diagram 9 Spacing of wall ties
(Par. 1.1.3.27)

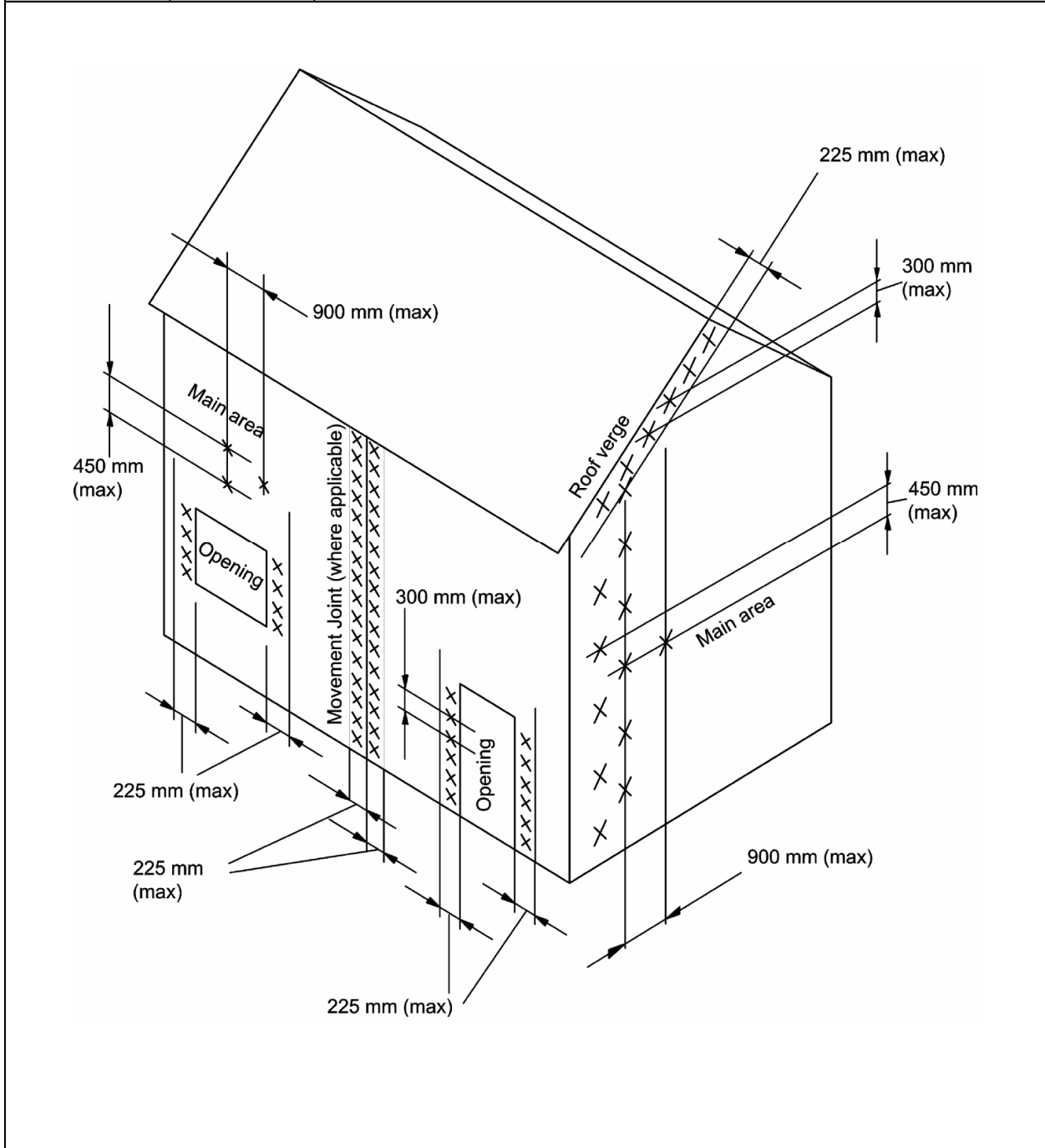

Part 4 - Proportions for masonry chimneys above the roof surface

Height to width relationship

1.1.4.1 Where a chimney is not supported by adequate ties or otherwise made secure, its height (H), measured from the level of the highest point of intersection with the roof surface, gutter or other part of the building and including any flue pot or terminal, should not be greater than X multiplied by W, provided that the density of the masonry is greater than 1800 kg/m³.

With reference to Diagram 1, Figure 1a):

X = 4.0 where the site wind speed is less than 26 m/s;

X = 3.5 where the site wind speed is greater than 26m/s.

W is the lesser horizontal dimension of the chimney measured at the same point of intersection (see Diagram 10).

The proportions given above are intended for general application and are valid when the associated building height to ridge level is not greater than that calculated by the procedure in Diagram 1. However, more slender chimneys may be built if they can be shown by calculation to be stable in the particular wind environment of the building.

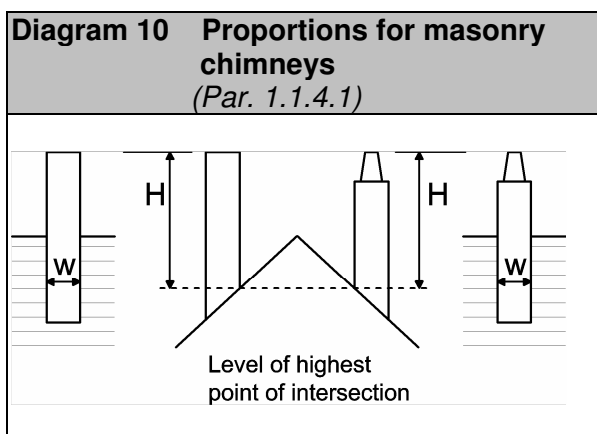

Part 5 - Strip foundations of plain concrete

Conditions relating to the subsoil

1.1.5.1 There should not be -

- made ground or wide variation in type of subsoil within the loaded area, or
- weaker type of soil at such a depth below the soil on which the foundation rests as could impair the stability of the structure.

Design provisions

1.1.5.2 The following design provisions relate to foundations -

- the foundations should be situated centrally under the wall;
- strip foundations should have minimum widths in accordance with *par. 1.1.5.3*;
- concrete should incorporate a cement to I.S. EN 197-1 and fine and coarse aggregate conforming to I.S. EN 12620:2002 + S.R. 16:2004 and be one of the following grades -
 - in accordance with Table NA.5 of I.S. EN 206-1:2002 for reinforced foundations, or
 - Class C12/15 (characteristic 28 day strength of 15 N/mm²) with minimum cement content 200 kg/m³ and maximum water cement ratio 0.85 for plain concrete unreinforced foundations in non-aggressive ground conditions (when volumetric mixing is required for small projects, a 1:7 cement/ aggregate mix may be used),
- minimum thickness T of concrete foundation should be 200 mm or P, whichever is the greater, where P is derived using Table 5 (see Diagram 11);

- (e) foundations stepped on elevation should overlap by:
- (i) twice the height of the step, or
 - (ii) the thickness of the foundation, or
 - (iii) 300 mm,
- whichever is greatest (see Diagram 12);
- (f) steps in foundations should not be of greater height than twice the thickness of the foundation and should course with walling material (see Diagram 12);
- (g) foundations for piers, buttresses and chimneys should project as indicated in Diagram 13, and the projection X should never be less than P.

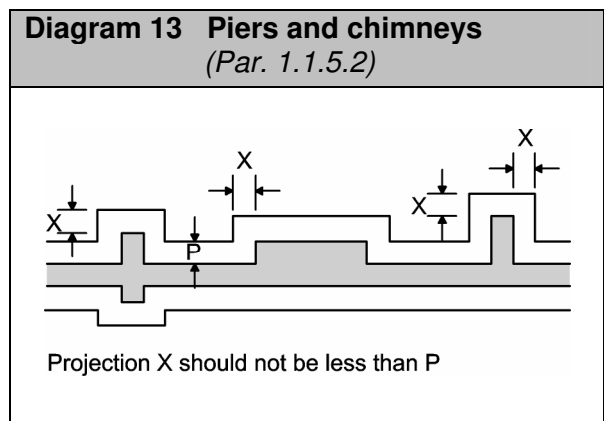
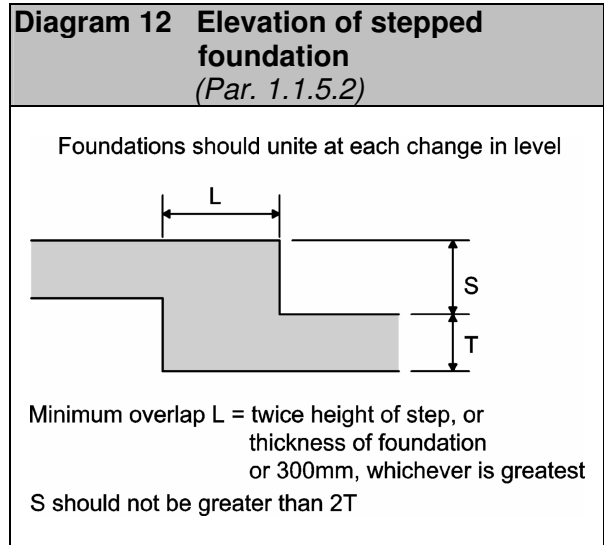
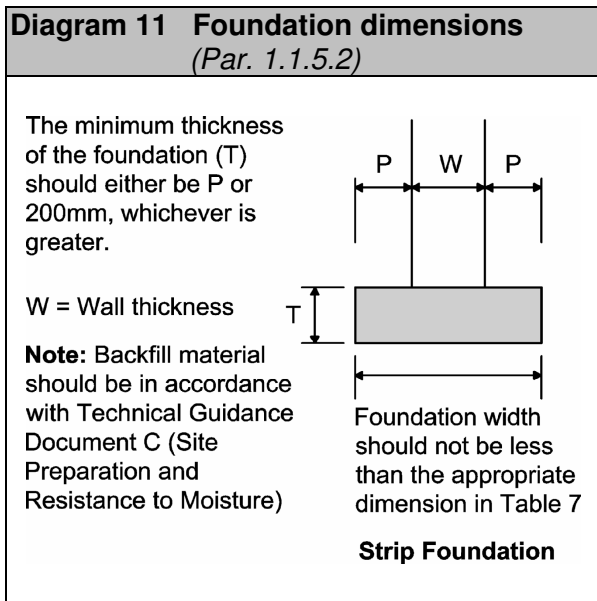

Minimum width of strip foundations

1.1.5.3 Providing the previous conditions relating to the subsoil (par. 1.1.5.1) and design provisions relating to the foundations (par. 1.1.5.2) are observed and the type and condition of subsoil is known and loading at the base of the wall is within acceptable limits, the recommended widths of foundations given in Table 5 may be used

Table 5 Minimum width of strip foundations

Type of subsoil	Condition of subsoil	Field test applicable	Total load of load-bearing walling not more than (kN/linear metre)				
			30	40	50	60	70
			Minimum width of strip foundation (mm)				
I rock	not inferior to sandstone, limestone or firm chalk	requires at least a pneumatic or other mechanically operated pick for excavation	In each case the width (wt) of wall plus 150 mm				
II gravel sand	compact compact	requires pick for excavation. A wooden peg 50 mm square in cross section hard to drive beyond 150 mm	400	400	500	600	650
III clay sandy clay boulder clay	stiff stiff stiff	cannot be moulded with the fingers and requires a pick or pneumatic or other mechanically operated spade for its removal	400	400	500	600	650
IV clay sandy clay boulder clay	firm firm firm	can be moulded by substantial pressure with the fingers and can be excavated with a spade	400	450	500	600	650
V sand silty sand clayey sand boulder clay	loose loose loose loose	can be excavated with a spade. A wooden peg 50 mm square in cross section can be easily driven	<p>Note: Where there is any doubt as to the condition of the subsoil, and always in the case of subsoil types V, VI and VII, an appropriate site investigation, on which the foundation design can be based, is essential.</p>				
VI silt clay sandy clay silty clay	soft soft soft soft	fairly easily moulded in the fingers and readily excavated					
VII silt clay sandy clay silty clay	very soft very soft very soft very soft	natural sample in winter conditions exudes between fingers when squeezed in fist					

Note: In no case should the width of the foundation be less than the total width of the wall plus 75 mm on each side.

Sub-section 2

Design and construction of all building types - codes, standards and references

Introduction

1.2.1 The following codes, standards and references are appropriate for all buildings and may be used to meet **Requirements A1 and A2** provided that:

- (a) the design and construction of a structure is in accordance with the relevant recommendations of the codes, standards and references, and
- (b) where alternative codes and standards have been listed, the whole of the design for the same material should normally be based on one of the codes only.

Codes, standards and references

Any reference to the Eurocodes must be taken to include reference to the relevant Irish National Annex.

Loading

Eurocode Basis of structural design

I.S. EN 1990: 2002

Eurocode 1: Actions on Structures

I.S. EN 1991-1-1: 2002

I.S. EN 1991-1-3: 2003

I.S. EN 1991-1-4: 2005

I.S. EN 1991-1-5: 2003

I.S. EN 1991-1-6: 2005

I.S. EN 1991-1-7: 2006

I.S. EN 1991-3: 2006

Structural work of reinforced, pre-stressed or plain concrete

Eurocode 2: Design of Concrete Structures

I.S. EN 1992-1-1: 2005

I.S. EN 1992-3: 2006

Execution standards

I.S. EN 13670: 2009

Structural work of steel

Eurocode 3: Design of Steel Structures

I.S. EN 1993-1-1: 2005

I.S. EN 1993-1-3: 2006

I.S. EN 1993-1-4: 2006

I.S. EN 1993-1-5: 2006

I.S. EN 1993-1-6: 2007

I.S. EN 1993-1-7: 2007

I.S. EN 1993-1-8: 2005

I.S. EN 1993-1-9: 2005

I.S. EN 1993-1-10: 2005

I.S. EN 1993-1-11: 2006

I.S. EN 1993-1-12: 2007

I.S. EN 1993-5: 2007

I.S. EN 1993-6: 2007

Execution standards

I.S. EN 1090-1:2009

I.S. EN 1090-2:2008+A1:2011

Structural work of composite steel and concrete construction

Eurocode 4: Design of Composite Concrete and Steel Structures

I.S. EN 1994-1-1: 2005

Execution standards

I.S. EN 13670: 2009

I.S. EN 1090-1: 2009

I.S. EN 1090-2: 2008+A1:2011

Structural work of timber

Eurocode 5: Design of Timber Structures

I.S. EN 1995-1-1: 2005

I.S. 440: 2009 (under revision)

Structural work of masonry

Eurocode 6: Design of Masonry Structures

I.S. EN 1996-1-1: 2005

I.S. EN 1996-2: 2006

I.S. EN 1996-3: 2006

prS.R. 325:yyyy (to be published by NSAI)

Foundations - General

Eurocode 7: Geotechnical Design

I.S. EN 1997-1: 2005

I.S. EN 1997-2: 2007

Execution standards

I.S. EN 1536: 2010

I.S. EN 1537: 2000

I.S. EN 1538: 2010

I.S. EN 12063: 1999

I.S. EN 12699:2000

I.S. EN 12715: 2000

I.S. EN 12716: 2001

I.S. EN 14199: 2005

I.S. EN 15237: 2007

I.S. EN 14679: 2005

I.S. EN 14731: 2005

I.S. EN 14475: 2006

I.S. EN 14490: 2010

Structural work of aluminium

Eurocode 9: Design of Aluminium Structures

I.S. EN 1999-1-1: 2007

I.S. EN 1999-1-3: 2007

I.S. EN 1999-1-4: 2007

I.S. EN 1999-1-5: 2007

Execution standards

I.S. EN 1090-1: 2009

I.S. EN 1090-3: 2008

Structural work of glass

BS 6262: 1982

BS 6262-1:2005

BS 6262-2:2005

BS 6262-3:2005

BS 6262-4: 2005

BS 6262-5: 2005

BS 6262-6: 2005

BS 6262-7: 2005

Appraisal of existing buildings

Appraisal of existing structures 3rd edition

Institution of Structural Engineers 2010.

Building Research Establishment Digest 366:
Structural appraisal of existing buildings for
change of use 1991.

Structural renovation of traditional buildings,
Report 111. Construction Industry Research
and Information Association (1994 reprint
with amendments).

Diagram 14 Basic snow load at 100 m Above Ordnance Datum (Extract from NA to I.S. EN 1991-1-3)

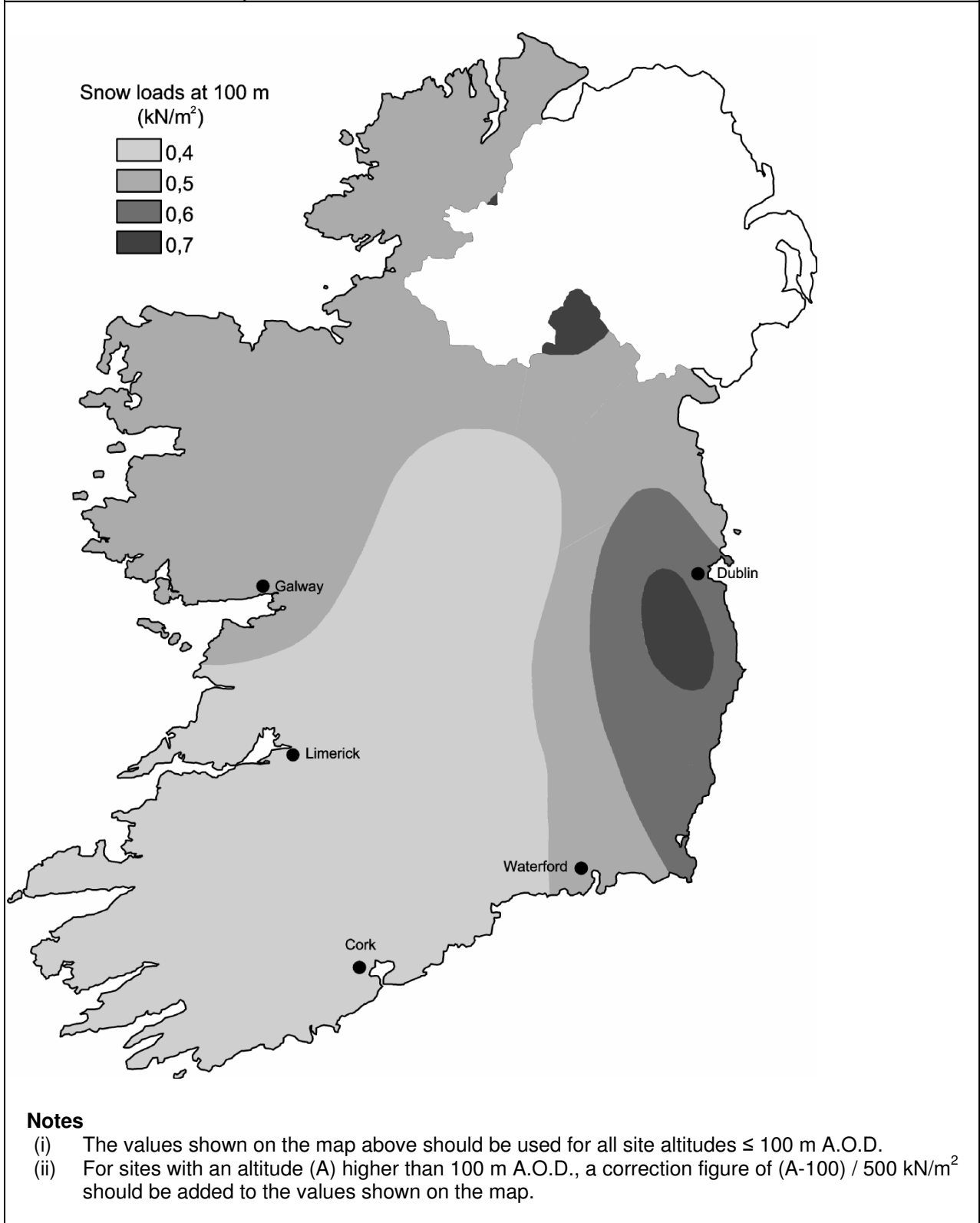

Sub-section 3

Recovering of existing roof structures and structural safety of external wall cladding

Recovering of existing roof structures

1.3.1 Where new roof coverings would impose higher loads on the roof structure or where the new material would be lighter than the original material, strengthening measures may be required. The following procedure is recommended:

- (a) arrange for a thorough structural survey of the existing roof structure and the vertical restraints;
- (b) check the dry mass per unit area of the proposed roof covering and compare it with that of the existing roof covering;
- (c) make allowance for the increase in load due to water absorption, e.g. 0.3% for oven dry slates and up to 10.5% for clay plain tiles and concrete tiles;
- (d) check if the roof structure is capable of sustaining the increased load or if the vertical restraints provided for the roof structure are adequate for the wind uplift (the nett uplift may increase due to the use of lighter roofing material and/or provision of new underlay);
- (e) provide appropriate strengthening measures such as:
 - (i) replacement of defective members and vertical restraints;
 - (ii) additional structural members such as trusses, rafters, bracings, purlins, etc. which are required to sustain increased loading;
 - (iii) restraining straps, additional ties and fixings to the walls to resist wind uplift.

Structural safety of external wall cladding

1.3.2 The remainder of this sub-section includes guidance for the design and construction of external wall cladding. Wall cladding presents a hazard if it becomes detached from the building. For the purposes of this section, cladding is deemed to include glazed curtain walling but not windows.

1.3.3 These provisions are not intended to provide guidance concerning the weather resistance of wall cladding which is included in Technical Guidance Document C, Site Preparation and Resistance to Moisture, or guidance on resistance to fire which is included in Technical Guidance Document B, Fire Safety.

1.3.4 Wall cladding should be capable of safely sustaining and transmitting to the supporting structure of the building all the actions which are liable to act on it.

1.3.5 Wall cladding should be securely fixed to and supported by the supporting structure of the building. The method used to secure the cladding to the structure should comprise both vertical support and horizontal restraint.

1.3.6 Provision should be made, where necessary, to accommodate differential movement of the cladding and the supporting structure of the building.

1.3.7 The cladding and its fixings including any support components should be of durable materials and the anticipated life of the fixings should not be less than that of the cladding. Where the fixings are not readily accessible for inspection and maintenance, particular care will be required in the choice of materials and standard of workmanship to be achieved (see Technical Guidance Document D). Fixings should be corrosion resistant and of a material type which is appropriate for the local environment.

Technical approach

Loading

1.3.8 Wind actions on the wall cladding should be derived from I.S. EN 1991-1-4. Due consideration should be given to local increases in wind suction arising from funnelling of wind through gaps between buildings. Forces imposed on wall cladding by ladders or access cradles for the purpose of maintenance should be derived from a consideration of the equipment likely to be used.

1.3.9 Where the wall cladding is required to support other fixtures such as handrails, or fittings such as antennae, signboards, etc., full account should be taken of the actions arising from such fixtures and fittings.

1.3.10 Where the wall cladding is required to function as pedestrian guarding to a stairway, ramp, vertical drop of 600 mm or greater or as a vehicle barrier, then account should be taken of the additional imposed loading, as stipulated in Technical Guidance Document K, Stairways, Ladders, Ramps and Guards.

1.3.11 Where the wall cladding is required to resist the horizontal loading from crowds, an appropriate recommended loading is given in I.S. EN 1991-1-1.

Fixings

1.3.12 The selection of fixings for securing cladding should be determined from consideration of the proven performance of the fixing and the risks associated with the particular application.

Designers should have particular regard for the following legislation and amendments thereto: Safety, Health and Welfare at Work (Construction) Regulations 2006 (S.I. No. 504 of 2006), relevant provisions of the Safety, Health and Welfare at Work Act 2005 (No. 10 of 2005) and the Safety, Health and Welfare at Work (General Application) Regulations 2007 (S.I. No. 299 of 2007).

The publication titled 'Code of practice for the design and installation of anchors – Health and Safety Authority 2010' provides practical guidance on the procedures for safe design and installation of anchors in accordance with the above legislation.

1.3.13 For design purposes, the strength of a fixing should be derived from tests using materials representative of the base material of the structure into which the fixing is to be anchored. Account should also be taken of any inherent weaknesses in the base material of the structure which may affect the design strength and durability of the fixing, e.g. cracks due to shrinkage or flexure, or voids in masonry construction.

Further guidance on fixings

1.3.14 Additional guidance on fixings is given in the following documents:

ETAG 001 Edition 1997 - Guidelines for European Technical Approval of Metal Anchors for use in Concrete – Amended November 2006, European Organisation for Technical Approvals (EOTA) www.eota.be

ETAG 029 Edition 2010 Guideline for European Technical Approval of metal injection anchors for use in masonry, European Organisation for Technical Approvals (EOTA) www.eota.be

BS 5080-1:1994

BS 5080-2:1986

BS 5427-1: 1996

1.3.15 Movement - Guidance is given in BS 8200: 1985 and prS.R. 325 on the means of providing for the differential movement between the wall cladding and the supporting structure of the building.

Codes and standards

1.3.16 The following Codes and Standards may be used in designing wall cladding:

General

BS 8200: 1985

The Institution of Structural Engineers' Report on 'Aspects of Cladding' dated 1995

Loading

I.S. EN 1990: 2002

I.S. EN 1991-1-1: 2002

I.S. EN 1991-1-4: 2005

Stone and concrete cladding

I.S. EN 1992-1-1: 2005

BS 8297: 2000

BS 8298-1: 2010

BS 8298-2: 2010

BS 8298-3: 2010

BS 8298-4: 2010

BS 8298-5: (In preparation)

Masonry cladding

prS.R. 325: yyyy (to be published by NSAI)

I.S. EN 1996-1-1: 2005

I.S. EN 1996-2: 2006

I.S. EN 1996-3: 2006

Steel cladding

I.S. EN 1993-1-1: 2005

I.S. EN 1993-1-3: 2006

I.S. EN 1993-1-5: 2006

I.S. EN 1993-1-6: 2007

I.S. EN 1993-1-8: 2005

I.S. EN 1993-1-10: 2005

Aluminium cladding

I.S. EN 1999-1-1: 2007

I.S. EN 1999-1-3: 2007

I.S. EN 1999-1-4: 2007

Timber cladding

I.S. EN 1995-1-1: 2005

I.S. 440:2009 (under revision)

External Timber Cladding 2nd Edition 2007,
TRADA

Profiled sheet cladding

BS 5427-1: 1996

Glass cladding

BS 5516-1:2004

BS 5516-2:2004

Note: The use of large panels of glass in cladding of walls and roofs where the cladding is not divided into small areas by load-bearing framing requires special consideration. Guidance is given in the following document:

The Institution of Structural Engineers' Report on 'Structural use of glass in buildings' dated 1999

Section 2

Disproportionate Collapse

Section 2 Disproportionate collapse

Disproportionate collapse. A3 (1) A building shall be designed and constructed, with due regard to the theory and practice of structural engineering, so as to ensure that in the event of an accident the structure will not be damaged to an extent disproportionate to the cause of the damage.

(2) For the purposes of sub-paragraph (1), where a building is rendered structurally discontinuous by a vertical joint, the building on each side of the joint may be treated as a separate building whether or not such joint passes through the substructure.

Introduction

2.1 All buildings must be designed to accommodate unforeseen or accidental actions in such a way as to prevent the extent of any resulting collapse being disproportionate to the cause of the collapse. Buildings should be designed so that they are robust which is defined in I.S. EN 1991-1-7 as the ability of a structure to withstand events like fire, explosions, impact or the consequences of human error without being damaged to an extent disproportionate to the original cause.

Disproportionate collapse

2.2 A building which is susceptible to disproportionate collapse is one where the effects of accidents and, in particular, situations where damage to small areas of a structure or failure of single elements could lead to collapse of major parts of the structure.

Buildings should be provided with a level of robustness by adopting the principles of risk analysis, categorising buildings, taking into account both the risk of the hazard and its consequences and providing additional measures commensurate to the level of risk and consequences of such collapse of the building. The risk level and accidental actions that should be considered when undertaking the structural design of a building for disproportionate collapse should be in

accordance with the recommendations of I.S. EN 1991-1-7 or the method set out below. Other additional material specific requirements may be outlined in I.S. EN 1992-1-1 to I.S. EN 1996-1-1 and I.S. EN 1999-1-1.

Any reference to Eurocodes must be taken to include the relevant Irish National Annex.

The **Requirement A3** will be met by adopting the following approach for ensuring that the building is sufficiently robust to sustain a limited amount of damage or failure, depending on the consequence class of the building, without collapse.

Step 1 - Determine the building consequence class from Table 6;

Step 2 - Assess additional measures;

Step 3 - Design and construct additional measures.

Step 1 - Determine building consequence class

2.3 With reference to Table 6, the issues to be considered with respect to assessing the consequence class (risk group) of a building are its occupancy level, use, the number of storeys and floor areas.

Step 2 - Assess additional measures

2.4 The additional measures which should be provided vary extensively according to building type and use. The actual measures should be designed in accordance with the relevant sections of the design codes, e.g. high rise hotels or apartment buildings or assembly buildings or grandstands require a different level of robustness than low rise buildings or storage buildings.

The additional measures which should be applied to buildings of the risk groups derived from Table 6 are set out below.

Consequence Class 1 buildings

Provided the building has been designed and constructed in accordance with the rules given in this Technical Guidance Document for meeting compliance with A1 and A2 in normal use, no additional measures are likely to be necessary.

Consequence Class 2a buildings (Lower Risk Group)

In addition to the Consequence Class 1 measures, provide effective horizontal ties, or effective anchorage of suspended floors to walls, as described in the codes and standards listed in par. 2.5, for framed and load-bearing wall construction.

Consequence Class 2b buildings (Upper Risk Group)

In addition to the Consequence Class 1 measures, provide effective horizontal ties for framed and load-bearing wall construction, together with effective vertical ties, in all supporting columns and walls. Horizontal and vertical ties should be in accordance with the codes and standards listed in par. 2.5.

Alternatively, check that upon the notional removal of each supporting column and each beam supporting one or more columns, or any nominal length of load-bearing wall (one at a time in each storey of the building) the building should remain stable and that the area of floor at any storey at risk of collapse should be not more than 15% of the floor

area of that storey or 100 m², whichever is smaller and does not extend further than the immediate adjacent storeys (see Diagram 15).

Where the notional removal (one at a time in each storey of the building) of such columns, beams supporting one or more columns, or any nominal lengths of load-bearing walls, would result in an extent of damage in excess of the above limit, then such elements should be designed as key elements (see par. 2.6).

Consequence Class 3 buildings

A systematic risk assessment of the building should be carried out taking into account as far as is reasonably practicable, all the normal hazards which can be foreseen together with any abnormal hazards.

Critical situations for design should be selected that reflect the conditions that can be reasonably foreseen as far as possible during the life of the building.

The structural form and concept, and any protective measures, should then be chosen and the detailed design of the structure and its elements undertaken in accordance with the recommendations in the standards given in par. 2.5.

Further guidance is given in Annexes A and B to I.S. EN 1997-1-7 and I.S. EN 1990

Step 3 - Design and construct additional measures

2.5 Details of the effective horizontal and vertical ties where appropriate together with the design approach for checking the integrity of the building following the notional removal of vertical members and the design of key elements are given in the following standards and their National Annexes:

I.S. EN 1990:2002+A1:2005
I.S. EN 1991-1-7:2006
I.S. EN 1992-1-1:2005
I.S. EN 1993-1-1:2005
I.S. EN 1994-1-1:2005
I.S. EN 1995-1-1:2005+A1:2008

I.S. EN 1996-1-1:2005
I.S. EN 1999-1-1:2007+A1:2009

where H is the storey height in metres.

Annex A of I.S. EN 1991-1-7 provides corresponding guidance.

Definitions

2.6 The following definitions apply to Section 2:

Key element – A key element is a structural member whose removal would cause damage in excess of the limits stipulated in par. 2.4 and should be capable of sustaining an accidental design loading of 34 kN/m^2 applied in the horizontal and vertical directions, in one direction at a time to the member and any attached components such as cladding, having regard to the ultimate strength of such components and their connections. Such accidental design loading should be applied in accordance with Expression 6.11 (b) of I.S. EN 1990 and may be a concentrated or distributed load (refer to Clause A.8 of I.S. EN 1991-1-7:2006).

Load-bearing construction – For the purposes of this Guidance the term 'load-bearing wall construction' includes masonry cross-wall construction and walls comprising close-centred timber or lightweight steel section studs.

Nominal length of load-bearing wall – The nominal length of load-bearing wall construction referred to for Consequence Class 2b buildings (Upper Risk Group) should be taken as follows:

- in the case of a reinforced concrete wall, the distance between lateral supports subject to a maximum length not exceeding $2.25H$;
- in the case of an external masonry wall or timber or steel-stud wall, the length measured between vertical lateral supports;
- in the case of an internal masonry wall, or timber or steel-stud wall, a length not exceeding $2.25H$;

Table 6 – Building Consequence Classes (Par. 2.2)	
Consequence Class	Building type and occupancy
1	Single occupancy houses not exceeding 4 storeys; Agricultural buildings; Buildings into which people rarely go, provided no part of the building is closer to another building, or area where people do go, than a distance of 1.5 times the building height.
2a Lower Risk Group	5 storey single occupancy houses; Hotels not exceeding 4 storeys; Flats, apartments and other residential buildings not exceeding 4 storeys; Offices not exceeding 4 storeys; Industrial buildings not exceeding 3 storeys; Retailing premises not exceeding 3 storeys of less than 1000 m ² floor area in each storey; Single storey educational buildings; All buildings not exceeding two storeys to which the public are admitted and which contain floor areas not exceeding 2000 m ² at each storey.
2b Upper Risk Group	Hotels, flats, apartments and other residential buildings greater than 4 storeys but not exceeding 15 storeys; Educational buildings greater than single storey but not exceeding 15 storeys; Retail premises greater than 3 storeys but not exceeding 15 storeys; Hospitals not exceeding 3 storeys; Offices greater than 4 storeys but not exceeding 15 storeys; All buildings to which the public are admitted and which contain floor areas exceeding 2000 m ² but not exceeding 5000 m ² at each storey; Car parking not exceeding 6 storeys.
3	All buildings defined above as Class 2 Lower and Upper Consequences Class that exceed the limits on area and number of storeys; All buildings to which members of the public are admitted in significant numbers; Stadia accommodating more than 5000 spectators; Buildings containing hazardous substances and /or processes
Notes	
(i) For buildings intended for more than one type of use the 'consequences class' should be that relating to the most onerous type	
(ii) In determining the number of storeys, basement storeys may be excluded provided such basement storeys fulfil the requirements of 'Consequences Class 2b Upper Risk Group'	

Diagram 15 Area at risk of collapse in the event of an accident
(Par. 2.4)

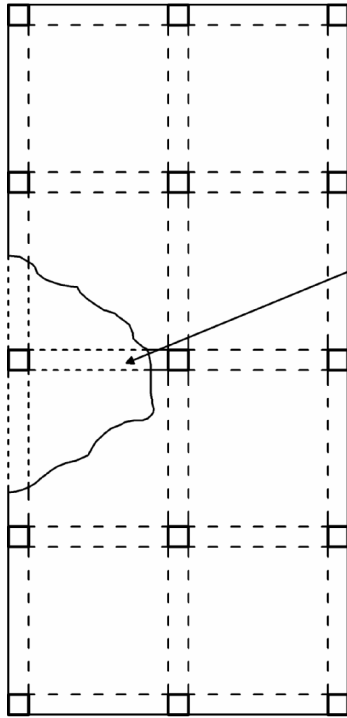

Plan

Area at risk of collapse limited to 15 per cent of the floor area of that storey of 100 square metres, whichever is less and the collapse does not extend further than the immediate adjacent storeys

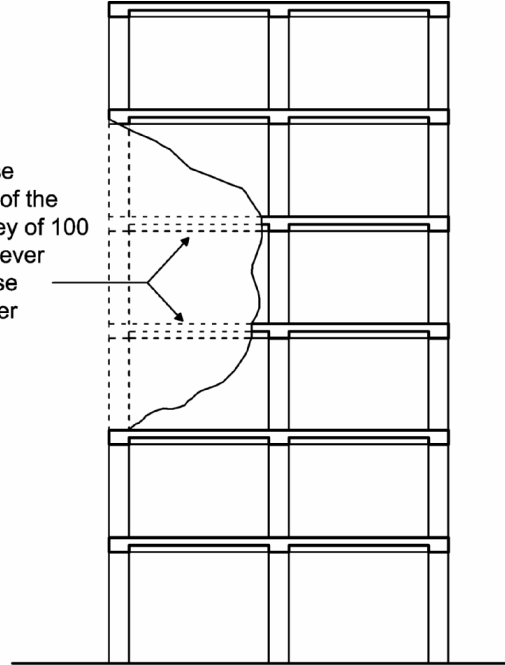

Elevation

Standards and publications

Note: Any reference to European Standards in this section must be taken to include reference to the relevant Irish National Annex.

Standards referred to:

I.S. 193:2006 Timber trusses for roofs

prS.R. 325:yyyy Recommendations for the design of masonry structures in Ireland to Eurocode 6 (to be published by NSAI)

I.S. 440:2009 Timber frame dwellings (under revision)

I.S. EN 197-1:2011 Cement - Part 1: Composition, specifications and conformity criteria for common cements

I.S. EN 206-1:2002 Concrete – Part 1: Specification, performance, production and conformity

I.S. EN 336:2003 Structural timber – Sizes, permitted deviations

I.S. EN 338:2009 Structural timber – Strength classes

I.S. EN 771-1:2011 Specification for masonry units – Part 1: Clay masonry units

I.S. EN 771-2:2011 Specification for masonry units – Part 2: Calcium silicate masonry units

I.S. EN 771-3:2011 Specification for masonry units – Part 3: Aggregate concrete masonry units (Dense and lightweight aggregates)

I.S. EN 771-4:2011 Specification for masonry units – Part 3: Autoclaved aerated concrete masonry units

I.S. EN 771-5:2011 Specification for masonry units – Part 5: Manufactured stone masonry units

I.S. EN 771-6:2011 Specification for masonry units – Part 6: Natural stone masonry units

I.S. EN 772-1:2011 Methods of test for masonry units – Part 1: determination of compressive strength

I.S. EN 845-1:2003+A1:2008 Specification for ancillary components for masonry – Part 1: Ties, tension straps, hangers and brackets

I.S. EN 845-2:2003 Specification for ancillary components for masonry – Part 2: Lintels

I.S. EN 998-2:2010 Specification for mortar for masonry – Part 2: Masonry mortar

I.S. EN 1090-1:2009/AC:2010 Execution of steel structures and aluminium structures - Part 1: Requirements for conformity assessment of structural components

I.S. EN 1090-2:2008+A1:2011 Execution of steel structures and aluminium structures - Part 2: Technical requirements for steel structures

I.S. EN 1090-3:2008 Execution of steel structures and aluminium structures - Part 3: Technical requirements for aluminium structures

I.S. EN 1536:2010 Execution of special geotechnical work - Bored piles

I.S. EN 1537:2000 Execution of special geotechnical work – Ground anchors

I.S. EN 1538:2010 Execution of special geotechnical work – Diaphragm walls

I.S. EN 1912:2004 + A4:2010 Structural timber – Strength classes – Assignment of visual grades and species

I.S. EN 12063:1999 Execution of special geotechnical work – Sheet pile walls

I.S. EN 12699:2000 Execution of special geotechnical work – Displacement piles

I.S. EN 12620:2002 Aggregates for concrete

I.S. EN 12715:2000 Execution of special geotechnical work – Grouting

I.S. EN 12716:2001 Execution of special geotechnical work – Jet grouting

I.S. EN 13670:2009 Execution of concrete structures

I.S. EN 14199:2005 Execution of special geotechnical work – Micropiles

I.S. EN 14475:2006/ COR 2006 Execution of special geotechnical work – Reinforced fill

I.S. EN 14490: 2010 Execution of special geotechnical work – Soil nailing

I.S. EN 14679:2005/ COR 2006 Execution of special geotechnical work – Deep mixing

I.S. EN 14731:2005 Execution of special geotechnical work – Ground treatment by deep vibration

I.S. EN 15237:2007 Execution of special geotechnical work – Vertical drainage

S.R. 16:2004 Guidance on the use of I.S. EN 12620:2002 – Aggregates for concrete

BS 1297: 1987 Specification for tongued and grooved softwood flooring

BS 5080-1:1994 Structural fixings in concrete and masonry — Part 1: Method of test for tensile loading

BS 5080-2:1986 Structural fixings in concrete and masonry — Part 2: Method of determination of resistance to loading in shear (AMD 7602)

BS 5427-1: 1996 Code of practice for the use of profiled sheet for roof and wall cladding on buildings - Part 1: Design

BS 5516-1:2004 Patent glazing and sloping glazing for buildings — Part 1: Code of practice for design and installation of sloping and vertical patent glazing

-
- BS 5516-2:2004 Patent glazing and sloping glazing for buildings — Part 2: Code of practice for sloping glazing
- BS 6262: 1982 Code of practice for glazing for buildings AMD 4063; AMD 4582; AMD 8279 (Partially superseded but remains current)
- BS 6262-1:2005 Glazing for buildings Part 1: General methodology for the selection of glazing
- BS 6262-2:2005 Glazing for buildings Part 2: Code of practice for energy, light and sound
- BS 6262-3:2005 Glazing for buildings Part 3: Code of practice for fire, security and wind loading
- BS 6262-4: 2005 Glazing for buildings Part 4: Code of practice for safety related to human impact
- BS 6262-5: 2005 Glazing for buildings Part 5: Code of practice for frame design considerations
- BS 6262-6: 2005 Glazing for buildings Part 6: Code of practice for special applications
- BS 6262-7: 2005 Glazing for buildings Part 7: Provision of information
- BS 6750: 1986 Specification for modular co-ordination in building
- BS 8200: 1985 Code of practice for design of non-loadbearing external vertical enclosures of buildings
- BS 8297: 2000 Code of practice for design and installation of non-loadbearing precast concrete cladding AMD 11064, AMD 13018
- BS 8298-1:2010 Code of practice for design and installation of natural stone cladding and lining – Part 1: General
- BS 8298-2:2010 Code of practice for the design and installation of natural stone cladding and lining – Part 2: Traditional handset external cladding
- BS 8298-3:2010 Code of practice for the design and installation of natural stone cladding and lining – Part 3: Stone-faced pre-cast concrete cladding systems
- BS 8298-4:2010 Code of practice for the design and installation of natural stone cladding and lining – Part 4: Rainscreen and stone on metal frame cladding systems
- BS 8298-5: (In preparation) Code of practice for the design and installation of natural stone cladding and lining – Part 5: Internal linings

Structural Eurocodes

Eurocode

I.S. EN 1990:2002 + A1 2005 Eurocode - Basis of structural design

Eurocode 1

I.S. EN 1991-1-1:2002+A1 2005 Eurocode 1 - Actions on structures – Part 1-1: General actions - Densities, self-weight, imposed loads for buildings

I.S. EN 1991-1-3:2003 Eurocode 1 - Actions on structures – Part 1-3: General actions - Snow loads

I.S. EN 1991-1-4:2005+A1 2010 Eurocode 1 - Actions on structures – Part 1-4: General actions - Wind actions

I.S. EN 1991-1-5:2003 Eurocode 1 - Actions on structures – Part 1-5: General actions - Thermal actions

I.S. EN 1991-1-6:2005 Eurocode 1 - Actions on structures – Part 1-6: General actions - Actions during execution

I.S. EN 1991-1-7:2006 Eurocode 1 - Actions on structures – Part 1-7: General actions - Accidental actions

I.S. EN 1991-3:2006 Eurocode 1 - Actions on structures – Part 3: Actions induced by cranes and machinery

Eurocode 2

I.S. EN 1992-1-1:2005 Eurocode 2 - Design of concrete structures – Part 1-1: General rules and rules for buildings

I.S. EN 1992-3:2006 Eurocode 2 - Design of concrete structures – Part 3: Liquid retaining and containing structures

Eurocode 3

I.S. EN 1993-1-1:2005 Eurocode 3 - Design of steel structures – Part 1-1: General rules and rules for buildings

I.S. EN 1993-1-3:2006 Eurocode 3 - Design of steel structures – Part 1-3: General rules - Supplementary rules for cold formed members and sheeting

I.S. EN 1993-1-4:2006 Eurocode 3 - Design of steel structures – Part 1-4: General rules - Supplementary rules for stainless steels

I.S. EN 1993-1-5:2006 Eurocode 3 - Design of steel structures – Part 1-5: Plated structural elements

I.S. EN 1993-1-6:2007 Eurocode 3 - Design of steel structures – Part 1-6: General - Strength and stability of shell structures

I.S. EN 1993-1-7:2007 Eurocode 3 - Design of steel structures – Part 1-7: Plated structures subject to out of plane loading

I.S. EN 1993-1-8:2005 Eurocode 3 - Design of steel structures – Part 1-8: Design of joints

I.S. EN 1993-1-9:2005 Eurocode 3 - Design of steel structures – Part 1-9: Fatigue

I.S. EN 1993-1-10:2005 Eurocode 3 - Design of steel structures – Part 1-10: Material toughness and through-thickness properties

I.S. EN 1993-1-11:2006 Eurocode 3 - Design of steel structures – Part 1-11: Design of structures with tension components

I.S. EN 1993-1-12:2007 Eurocode 3 - Design of steel structures – Part 1-12: Additional rules for the extension of EN 1993 up to grades S700

I.S. EN 1993-5:2007 Eurocode 3 - Design of steel structures – Part 5: Piling

I.S. EN 1993-6:2007 Eurocode 3 - Design of steel structures – Part 6: Crane supporting structures

Eurocode 4

I.S. EN 1994-1-1: 2005 Eurocode 4 - Design of composite concrete and steel structures – Part 1-1: General rules and rules for buildings

Eurocode 5

I.S. EN 1995-1-1:2005+A1:2008 Eurocode 5 - Design of timber structures – Part 1-1: Common rules and rules for buildings

Eurocode 6

I.S. EN 1996-1-1:2005 Eurocode 6 - Design of masonry structures – Part 1-1: Rules for reinforced and un-reinforced masonry

I.S. EN 1996-2:2006 Eurocode 6 - Design of masonry structures – Part 2: Design considerations, selection of materials and execution

I.S. EN 1996-3:2006 Eurocode 6 - Design of masonry structures – Part 3: Simplified calculations methods

Eurocode 7

I.S. EN 1997-1: 2005 Eurocode 7 - Geotechnical design – Part 1: General rules

I.S. EN 1997-2: 2005 Eurocode 7 - Geotechnical design – Part 2: Ground investigation and testing

Eurocode 9

I.S. EN 1999-1-1:2007+A1:2009 Eurocode 9 - Design of aluminium structures – Part 1-1: General structural rules

I.S. EN 1999-1-3:2007 Eurocode 9 - Design of aluminium structures – Part 1-3: Additional rules for structures susceptible to fatigue

I.S. EN 1999-1-4:2007 Eurocode 9 - Design of aluminium structures – Part 1-4: Supplementary rules for trapezoidal sheeting

I.S. EN 1999-1-5:2007 Eurocode 9 - Design of aluminium structures – Part 1-5: Supplementary rules for shell structures

Publications referred to:

Appraisal of existing structures 3rd edition, Institution of Structural Engineers 2010

Building Research Establishment Digest 366: Structural appraisal of existing buildings for change of use 1991

Code of practice for the design and installation of anchors – Health and Safety Authority 2010
ETAG No. 001 1997

ETAG 001 Edition 1997 Guideline for European Technical Approvals of Metal Anchors for use in Concrete – Amended November 2006, European Organisation for Technical Approvals (EOTA) www.eota.be

ETAG 029 Edition 2010 Guideline for European Technical Approval of metal injection anchors for use in masonry, European Organisation for Technical Approvals (EOTA) www.eota.be

Structural renovation of traditional buildings, Report 111 Construction Industry Research and Information Association (1994 reprint with amendments)

External Timber Cladding 2nd Edition 2007, TRADA

Other standards and publications

BS 6180: 2011 Barriers in and about buildings – Code of practice

BS 8219: 2001 Installation of sheet roof and wall coverings — Profiled fibre cement – Code of practice

Practical guide to structural robustness and disproportionate collapse in buildings, Institution of Structural Engineers 2010

ISBN 978-1-4064-2702-8



9 781406 427028

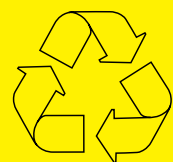

Printed on recycled paper containing a minimum of 75% post-consumer waste